

Pursuing the Ideal Compact Inverter

# WJ200 Series

Designed for excellent performance and user friendliness



# Industry-leading Levels of Performance

## 1 High starting torque of 200% or greater achieved by sensorless vector control (when sized for heavy duty).

Integrated auto-tuning function for easy sensorless vector control realizes high torque suitable for applications requiring it such as crane hoists, lifts, elevators, etc.

### Example of Torque Characteristics

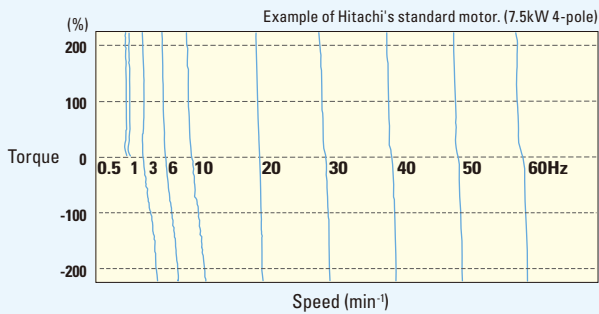

Auto-tuning to perform sensorless vector control can now be easily done.

## 2 Speed regulation at low-speed is greatly improved. – Fluctuation is 1/2\* compared with the previous model. –

Speed regulation at low speed has been drastically improved to enhance process stability and precision.

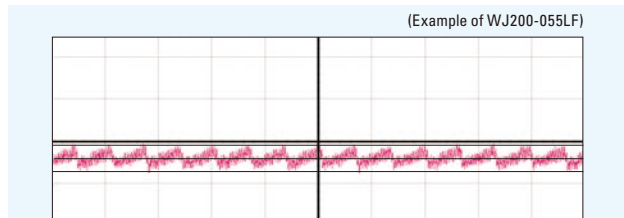

- Frequency commanded by the inverter: 0.5Hz.
- Motor: Hitachi's standard 3-phase 5.5kW 4-pole totally enclosed type motor.

\* WJ200: 5min<sup>-1</sup>, Previous model: 13min<sup>-1</sup>

## 3 Trip avoidance functions



Minimum time deceleration function, over-current suppress function and DC bus AVR function are incorporated. The functions reduce nuisance tripping. Improved torque limiting/current limiting function enables a load limit to protect machine and equipment.

(Example of WJ200-075LF)

### Minimum time deceleration Function

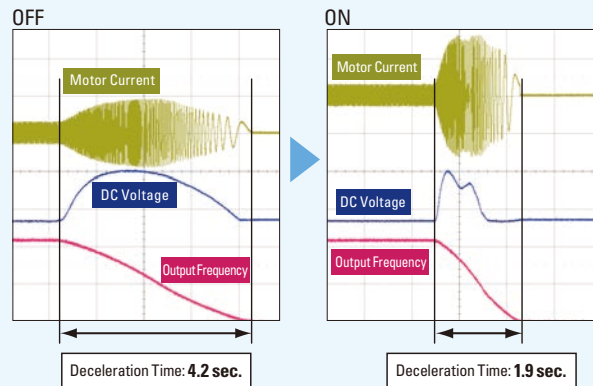

2.3 sec. reduction of deceleration time without a braking resistor is achieved when the function is active.

### Over-current Suppress Function\*

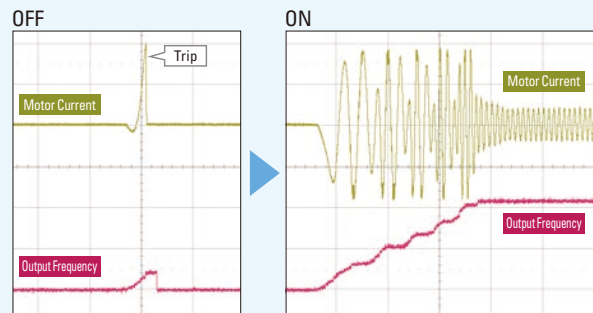

\*Turn off this function for lifting equipment.

## Model Name Indication

# WJ200 – 001 L F

Series Name ————— with Digital Operator

Applied Motor Capacity  
001: 0.1kW – 150: 15kW

Power Source  
M:1-phase 100V class  
S:1-phase 200V class  
L:3-phase 200V class  
H:3-phase 400V class



## Model Configuration

Model Name WJ200-xxx	1-phase 100V class		1-phase 200V class		3-phase 200V class		3-phase 400V class	
	CT	VT	CT	VT	CT	VT	CT	
001		0.2	0.1	0.2	0.1			
002		0.4	0.2	0.4	0.2			
004	0.4	0.55	0.4	0.75	0.4	0.75	0.4	
007	0.75	1.1	0.75	1.1	0.75	1.5	0.75	
015		2.2	1.5	2.2	1.5	2.2	1.5	
022		3.0	2.2	3.0	2.2	3.0	2.2	
030						4.0	3.0	
037				5.5	3.7			
040						5.5	4.0	
055				7.5	5.5	7.5	5.5	
075				11	7.5	11	7.5	
110				15	11	15	11	
150				18.5	15	18.5	15	

## 4 Simple positioning control (when feedback signal is used.)

**NEW**

When simple positioning function is activated, speed control operation or positioning control operation is selectable via intelligent input. While the [SPD] input is ON, the current position counter is held at 0. When [SPD] is OFF, the inverter enters positioning control operation and the position counter is active.

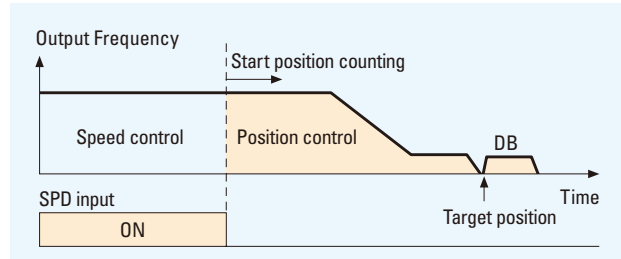

## 5 Induction motor & Permanent magnetic motor\* control with one inverter (corresponds more than Ver.2.0)

**NEW**

The WJ200 inverter can drive both induction motors (IM) and permanent magnetic motors (PM). Energy conservation and miniaturization can be achieved using PM motors. Moreover, one inverter used for two types of motor.

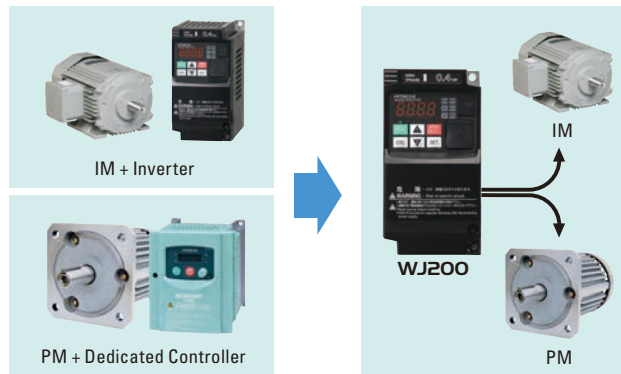

\*Permanent magnet motor control function of WJ200 is for variable torque application such as fan and pump.

## Global standards

### 1 Conformity to global standards

CE, UL, c-UL, c-Tick approvals.  
(1-phase 100V class is for UL and cUL only)



### 2 Sink / source logic is standard

Logic input and output terminal can be configured for sink or source logic.

### 3 Wide input power voltage range

Input voltage 240V for 200V class and 480V for 400V class as standard.

## Index

Features	P2-5
Standard Specifications	P6
General Specifications	P7
Dimensions	P8
Operation and Programming	P9
Terminal (Arrangements/Functions)	P10-11
Function List	P12-20
Protective Functions	P21
Connecting Diagram	P22-23
Connecting to PLC	P24
Wiring and Accessories	P25
For Correct Operation	P26-27

Pursuing the Ideal Compact Inverter

# WJ200

Designed for excellent performance and user friendliness

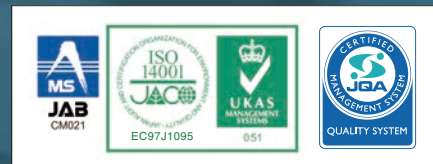

# Pursuit of Ease of Use

## 1 Easy sequence [EzSQ] programming function



Sequence operation is realized by downloading to an inverter a program created with Hitachi's EzSQ software. User program can be compiled on EzSQ software on a PC. External components can be simplified or eliminated, resulting in cost-savings.

### ● EzSQ Example: Energy cost saving by speed reduction.

- Daytime: Motor speed is automatically reduced to reduce demand during peak hours.
- Nighttime: Motor speed is increased to take advantage of off-peak power rates.

### Example of driving program

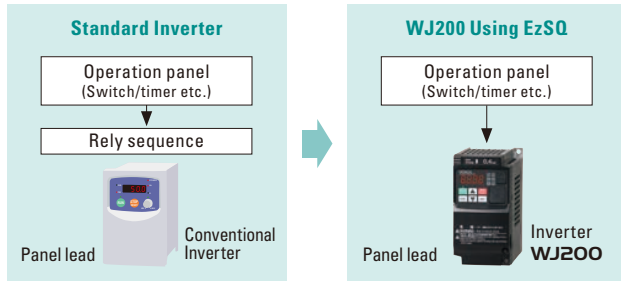
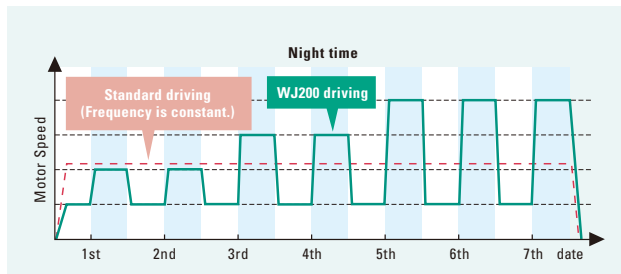

## 2 Safe stop function



WJ200 conforms to the applicable safety standards and corresponds to Machinery Directive of Europe. Shuts down the inverter by hardware, bypassing the CPU, to achieve reliable safe stop function. The safety standard can be met at a low cost.

(ISO13849-1 Category 3 / IEC60204-1 Stop Category 0)

\*1-phase 100V class is not certified.

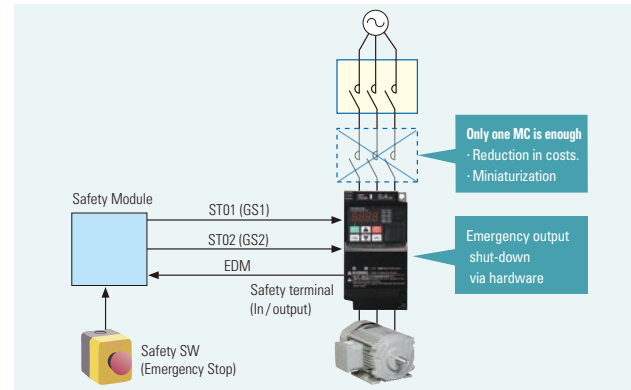

## 3 Password function



The WJ200 inverter has a password function to prevent changing parameters or to hide some or all parameters.

# Ease of Maintenance

## 1 Long life time components (Design life time 10 years or more\*)



Design lifetime 10 Years or more for DC bus capacitors and cooling fan.  
Cooling fan ON/OFF control function for longer fan life.

\*Ambient temperature : Average 40°C (no corrosive gases, oil mist or dust)  
Design lifetime is calculated, and not guaranteed.

## 2 Life time warning function



WJ200 diagnoses lifetime of DC bus capacitors and cooling fan(s).

## 3 Easy-removable cooling fan

The cooler fan can be exchanged without special tools.



Top cover can be removed with fingertips.



Remove cooling fan after disconnecting power plug.

# Environmental Friendliness

## 1 Micro surge voltage suppress function

Hitachi original PWM control method limits motor terminal voltage to less than twice inverter DC bus voltage. Lower than Hitachi motor max. insulation voltage (1,250V)

(During regeneration, the motor terminal voltage may exceed the motor maximum insulation voltage (1,250V))

### Motor terminal voltage

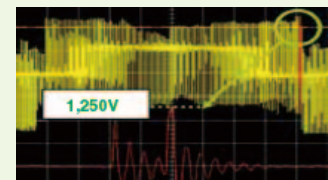

E=625V cable:100m

## 4 Network compatibility & External ports NEW

A serial RS485 Modbus/RTU port is standard. The WJ200 can communicate via DeviceNet and CCLink with optional expansion card. USB (Mini-B connector) port and RS422 (RJ45 connector) port are standard.

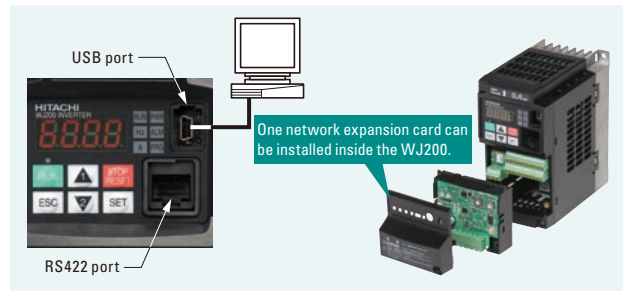

## 5 Ease of wiring NEW

Screw-less terminals (control circuit terminals) spring-loaded, for use with solid or stranded wire with ferrules.

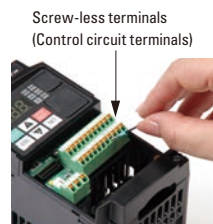

## 6 Easy to maintain NEW

### Easy selection of displayed parameters

- **Data comparison function**  
Display parameters changed from default setting.
- **Basic display**  
Display most frequently used parameters.
- **Quick display**  
Display 32 user-selected parameters.
- **User-changed parameter display**  
Store automatically and display the parameters changed by the user (Up to 32 sets); can also be used as change history.
- **Active parameter display**  
Display those parameters which are enabled.

## 7 Side-by-side installation

Inverters can be installed with no space between them to save space in the panel.

\*Ambient temperature 40°C max., individual mounting.



## 8 Easy adjustment of frequency

Pot for frequency adjustment is available as option kit.

Pot for Frequency Adjustment



## Various Versatile Functions

### 2 EU RoHS compliant

Environment-friendly inverter meets RoHS requirements (ordered items).

### 3 Improvement of environment

Varnish coating of internal PC board is standard.  
(Logic PCB and I/F PCB are excluded.)

### 1 Dual rating NEW

WJ200 can be used for both heavy and normal duty. One-frame-size smaller WJ200 can be applicable to certain applications.

\*1-phase 100V class is only with CT.

### 2 Watt-hour monitor NEW

Energy consumption is displayed in kwh.

### 3 Output monitoring NEW

(2 terminals)

Two monitor output terminals (Analog 0–10VDC (10-bit), pulse train (0–10VDC, max 32kHz)).

### 4 Built-in BRD circuit

Built-in BRD circuit for all models (Optional resistor).

### 5 EzCOM (Peer-to-Peer communication) NEW

WJ200 supports Peer-to-Peer communication between multiple inverters. One administrator inverter is necessary in the network, and the other inverters act as master or slave.

### 6 Flexible display functions NEW

**Automatic return to the initial display:** 10 min. after the last key operation, display returns to the initial parameter set.

**Display limitation:** Show only the contents of display parameter.

**Dual monitor:** Two arbitrary monitor items can be set. Parameters are switched by up/down keys.

# Standard Specifications

## 1-phase 100V class (only with CT)

Models WJ200-		004MF	007MF
Applicable motor size *1	kW	0.4	0.75
	HP	1/2	1
Rated capacity (kVA)	100V	1.0	1.7
	120V	1.2	2.0
Input Rating	Rated input voltage (V)	1-phase: 200V-10% to 120V +10%, 50/60Hz ±5%	
	Rated input current (A)	14	24
Output Rating	Rated output voltage (V) *2	3-phase: 200 to 240V (proportional to input voltage)	
	Rated output current (A)	3.5	5.0
Minimum value of resistor (Ω)		100	50
Weight	kg	1.1	1.6
	lb	2.4	3.5

## 1-phase 200V class

Models WJ200-		001SF	002SF	004SF	007SF	015SF	022SF	
Applicable motor size *1	kW	VT	0.2	0.4	0.55	1.1	2.2	3.0
		CT	0.1	0.2	0.4	0.75	1.5	2.2
	HP	VT	1/4	1/2	3/4	1.5	3	4
		CT	1/8	1/4	1/2	1	2	3
Rated capacity (kVA)	200V	VT	0.4	0.6	1.2	2.0	3.3	4.1
		CT	0.2	0.5	1.0	1.7	2.7	3.8
	240V	VT	0.4	0.7	1.4	2.4	3.9	4.9
		CT	0.3	0.6	1.2	2.0	3.3	4.5
Input Rating	Rated input voltage (V)	1-phase: 200V-15% to 240V +10%, 50/60Hz ±5%						
	Rated input current (A)	VT	2.0	3.6	7.3	13.8	20.2	24.0
		CT	1.3	3.0	6.3	11.5	16.8	22.0
Output Rating	Rated output voltage (V) *2	3-phase: 200 to 240V (proportional to input voltage)						
	Rated output current (A)	VT	1.2	1.9	3.5	6.0	9.6	12.0
		CT	1.0	1.6	3.0	5.0	8.0	11.0
Minimum value of resistor (Ω)		100	100	100	50	50	35	
Weight	kg	1.0	1.0	1.1	1.6	1.8	1.8	
	lb	2.2	2.2	2.4	3.5	4.0	4.0	

## 3-phase 200V class

Models WJ200-		001LF	002LF	004LF	007LF	015LF	022LF	037LF	055LF	075LF	110LF	150LF
Applicable motor size *1	kW	VT	0.2	0.4	0.75	1.1	2.2	3.0	5.5	7.5	11	18.5
		CT	0.1	0.2	0.4	0.75	1.5	2.2	3.7	5.5	7.5	11
	HP	VT	1/4	1/2	1	1.5	3	4	7.5	10	15	25
		CT	1/8	1/4	1/2	1	2	3	5	7.5	10	15
Rated capacity (kVA)	200V	VT	0.4	0.6	1.2	2.0	3.3	4.1	6.7	10.3	13.8	19.3
		CT	0.2	0.5	1.0	1.7	2.7	3.8	6.0	8.6	11.4	16.2
	240V	VT	0.4	0.7	1.4	2.4	3.9	4.9	8.1	12.4	16.6	23.2
		CT	0.3	0.6	1.2	2.0	3.3	4.5	7.2	10.3	13.7	19.5
Input Rating	Rated input voltage (V)	3-phase: 200V-15% to 240V +10%, 50/60Hz ±5%										
	Rated input current (A)	VT	1.2	1.9	3.9	7.2	10.8	13.9	23.0	37.0	48.0	68.0
		CT	1.0	1.6	3.3	6.0	9.0	12.7	20.5	30.8	39.6	57.1
Output Rating	Rated output voltage (V) *2	3-phase: 200 to 240V (proportional to input voltage)										
	Rated output current (A)	VT	1.2	1.9	3.5	6.0	9.6	12.0	19.6	30.0	40.0	56.0
		CT	1.0	1.6	3.0	5.0	8.0	11.0	17.5	25.0	33.0	47.0
Minimum value of resistor (Ω)		100	100	100	50	50	35	35	20	17	17	10
Weight	kg	1.0	1.0	1.1	1.2	1.6	1.8	2.0	3.3	3.4	5.1	7.4
	lb	2.2	2.2	2.4	2.6	3.5	4.0	4.4	7.3	7.5	11.2	16.3

## 3-phase 400V class

Models WJ200-		004HF	007HF	015HF	022HF	030HF	040HF	055HF	075HF	110HF	150HF
Applicable motor size *1	kW	VT	0.75	1.5	2.2	3.0	4.0	5.5	7.5	11	18.5
		CT	0.4	0.75	1.5	2.2	3.0	4.0	5.5	7.5	11
	HP	VT	1	2	3	4	5	7.5	10	15	25
		CT	1/2	1	2	3	4	5	7.5	10	15
Rated capacity (kVA)	200V	VT	1.3	2.6	3.5	4.5	5.7	7.3	11.5	15.1	20.4
		CT	1.1	2.2	3.1	3.6	4.7	6.0	9.7	11.8	15.7
	240V	VT	1.7	3.4	4.4	5.7	7.3	9.2	14.5	19.1	25.7
		CT	1.4	2.8	3.9	4.5	5.9	7.6	12.3	14.9	19.9
Input Rating	Rated input voltage (V)	3-phase: 380V-15% to 480V +10%, 50/60Hz ±5%									
	Rated input current (A)	VT	2.1	4.3	5.9	8.1	9.4	13.3	20.0	24.0	38.0
		CT	1.8	3.6	5.2	6.5	7.7	11.0	16.9	18.8	29.4
Output Rating	Rated output voltage (V) *2	3-phase: 380 to 480V (proportional to input voltage)									
	Rated output current (A)	VT	2.1	4.1	5.4	6.9	8.8	11.1	17.5	23.0	31.0
		CT	1.8	3.4	4.8	5.5	7.2	9.2	14.8	18.0	24.0
Minimum value of resistor (Ω)		180	180	180	100	100	100	70	70	70	35
Weight	kg	1.5	1.6	1.8	1.9	1.9	2.1	3.5	3.5	4.7	5.2
	lb	3.3	3.5	4.0	4.2	4.2	4.6	7.7	7.7	10.4	11.5

\*1: The applicable motor refers to Hitachi standard 3-phase motor (4p). When using other motors, care must be taken to prevent the rated motor current (50/60Hz) from exceeding the rated output current of the inverter.

\*2: The output voltage varies as the main supply voltage varies (except when using the AVR function). In any case, the output voltage cannot exceed the input power supply voltage.

## General Specifications

Item		General Specifications		
Protective housing *3		IP20		
Control method		Sinusoidal Pulse Width Modulation (PWM) control		
Carrier frequency		2kHz to 15kHz (derating required depending on the model)		
Output frequency range *4		0.1 to 400Hz		
Frequency accuracy		Digital command: $\pm 0.01\%$ of the maximum frequency Analog command: $\pm 0.2\%$ of the maximum frequency (25°C $\pm 10^\circ\text{C}$ )		
Frequency setting resolution		Digital: 0.01Hz; Analog: max. frequency / 1000		
Volt. / Freq. characteristic		V/f control (constant torque, reduced torque, free-V / F): base freq. 30Hz – 400Hz adjustable, Sensorless vector control, Closed loop control with motor encoder feedback (only V/f control).		
Overload capacity		Dual rating*6: CT (Heavy duty): 60 sec. @150% VT (Normal duty): 60 sec. @120%		
Acceleration / deceleration time		0.01 to 3600 seconds, linear and S-curve accel / decel, second accel / decel setting available		
Starting torque		200% @0.5Hz (sensorless vector control)		
DC braking		Variable operating frequency, time, and braking force		
Input signal	Freq. setting	Operator panel	$\Delta$ / $\nabla$ keys / Value settings	
		External signal *7	0 to 10 VDC (input impedance 10k $\Omega$ ), 4 to 20mA (input impedance 100 $\Omega$ ), Potentiometer (1k to 2k $\Omega$ , 2W)	
		Via network	RS485 ModBus RTU, other network option	
	FWD / REV run	Operator panel	Run / Stop (Forward / Reverse run change by command)	
		External signal *7	Forward run / stop, Reverse run / stop	
		Via network	RS485 ModBus RTU, other network option	
	Intelligent input terminal	Terminals	7 terminals, sink / source changeable by a short bar	
		Functions	FW (forward run command), RV (reverse run command), CF1 – CF4 (multi-stage speed setting), JG (jog command), DB (external braking), SET (set second motor), 2CH (2-stage accel. / decel. command), FRS (free run stop command), EXT (external trip), USP (startup function), CS (commercial power switchover), SFT (soft lock), AT (analog input selection), RS (reset), PTC (thermistor thermal protection), STA (start), STP (stop), F / R (forward / reverse), PID (PID disable), PIDC (PID reset), UP (remote control up function), DWN (remote control down function), UDC (remote control data clear), OPE (operator control), SF1 – SF7 (multi-stage speed setting; bit operation), OLR (overload restriction), TL (torque limit enable), TRQ1 (torque limit changeover1), TRQ2 (torque limit changeover2), BOK (Braking confirmation), LAC (LAD cancellation), PCLR (position deviation clear), ADD (add frequency enable), F-TM (force terminal mode), ATR (permission of torque command input), KHC (Cumulative power clear), M11 – M17 (general purpose inputs for EzSQ), AHD (analog command hold), CP1 – CP3 (multistage-position switches), ORL (limit signal of zero-return), ORG (trigger signal of zero-return), SPD (speed/position changeover), GS1,GS2 (STO inputs, safety related signals), 485 (Starting communication signal), PRG (executing EzSQ program), HLD (retain output frequency), ROK (permission of run command), EB (rotation direction detection of B-phase), DISP (display limitation), NO (no function)	
	Output signal	Intelligent output terminal	Functions	RUN (run signal), FA1 – FA5 (frequency arrival signal), OL,OL2 (overload advance notice signal), OD (PID deviation error signal), AL (alarm signal), OTQ (over / under torque threshold), UV (under-voltage), TRQ (torque limit signal), RNT (run time expired), ONT (power ON time expired), THM (thermal warning), BRK (brake release), BER (brake error), ZS (0Hz detection), DSE (speed deviation excessive), POK (positioning completion), ODC (analog voltage input disconnection), OIdc (analog current input disconnection), FBV (PID second stage output), NDC (network disconnect detection), LOG1 – LOG3 (Logic output signals), WAC (capacitor life warning), WAF (cooling fan warning), FR (starting contact), OHF (heat sink overheat warning), LOC (Low load), MO1 – MO3 (general outputs for EzSQ), IRDY (inverter ready), FWR (forward operation), RVR (reverse operation), MJA (major failure), WCO (window comparator O), WCOI (window comparator OI), FREF (frequency command source), REF (run command source), SETM (second motor in operation), EDM (STO (safe torque off) performance monitor), OP (option control signal), NO (no function)
			Monitor output (analog)	Output freq., output current, output torque, output voltage, input power, thermal load ratio, LAD freq., heat sink temperature, general output (EzSQ)
Pulse train output (0 – 10VDC, 32kHz max.)		[PWM output] Output freq., output current, output torque, output voltage, input power, thermal load ratio, LAD freq., heat sink temperature, general output (EzSQ) [Pulse train output] Output frequency, output current, pulse train input monitor		
Alarm output contact		ON for inverter alarm (1c contacts, both normally open or closed available.)		
Other functions		Free-V/f, manual/automatic torque boost, output voltage gain adjustment, AVR function, reduced voltage start, motor data selection, auto-tuning, motor stabilization control, reverse running protection, simple position control, simple torque control, torque limiting, automatic carrier frequency reduction, energy saving operation, PID function, non-stop operation at instantaneous power failure, brake control, DC injection braking, dynamic braking (BRD), frequency upper and lower limiters, jump frequencies, curve accel and decel (S, U, inverted U,EL-S), 16-stage speed profile, fine adjustment of start frequency, accel and decel stop, process jogging, frequency calculation, frequency addition, 2-stage accel / decel, stop mode selection, start / end freq., analog input filter, window comparators, input terminal response time, output signal delay / hold function, rotation direction restriction, stop key selection, software lock, safe stop function, scaling function, display restriction, password function, user parameter, initialization, initial display selection, cooling fan control, warning, trip retry, frequency pull-in restart, frequency matching, overload restriction, over current restriction, DC bus voltage AVR		
Protective function		Over-current, over-voltage, under-voltage, overload, brake resistor overload, CPU error, memory error, external trip, USP error, ground fault detection at power on, temperature error, internal communication error, driver error, thermistor error, brake error, safe stop, overload at low speed, modbus communication error, option error, encoder disconnection, speed excessive, EzSQ command error, EzSQ nesting error, EzSQ execution error, EzSQ user trip		
Operating environment	Temperature	Operating (ambient): -10 to 50°C / Storage: -20 to 65°C *8		
	Humidity	20 to 90% humidity (non-condensing)		
	Vibration *9	5.9m/s <sup>2</sup> (0.6G), 10 to 55 Hz		
	Location	Altitude 1,000m or less, indoors (no corrosive gasses or dust)		
Coating color		Black		
Options		Remote operator unit, cables for the units, braking unit, braking resistor, AC reactor, DC reactor, EMC filter		

\*3: The protection method conforms to JEM 1030.

\*4: To operate the motor beyond 50 / 60Hz, consult the motor manufacturer for the maximum allowable rotation speed.

\*5: The braking torque via capacitive feedback is the average deceleration torque at the shortest deceleration (stopping from 50 / 60Hz as indicated). It is not continuous regenerative braking torque. The average deceleration torque varies with motor loss. This value decreases when operating beyond 50Hz. If a large regenerative torque is required, the optional regenerative braking unit and a resistor should be used.

\*6: 1-phase 100V class is only with CT.

\*7: The frequency command is the maximum frequency at 9.8V for input voltage 0 to 10VDC, or at 19.6mA for input current 4 to 20mA. If this characteristic is not satisfactory for your application, contact your Hitachi representative.

\*8: The storage temperature refers to the short-term temperature during transportation.

\*9: Conforms to the test method specified in JIS C0040 (1999). For the model types excluded in the standard specifications, contact your Hitachi sales representative.

# Dimensions

[Unit: mm(inch)]  
Inches for reference only

- WJ200-004MF
- WJ200-001SF-004SF
- WJ200-001LF-007LF

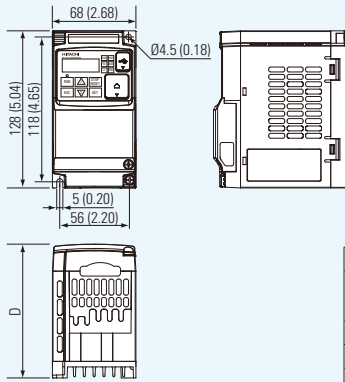

Model	D
001SF, 002SF 001LF, 002LF	109 (4.29)
004SF, 004LF	122.5 (4.82)
004MF	132.5 (5.22)
007LF	145.5 (5.73)

- WJ200-055LF
- WJ200-075LF
- WJ200-055HF
- WJ200-075HF

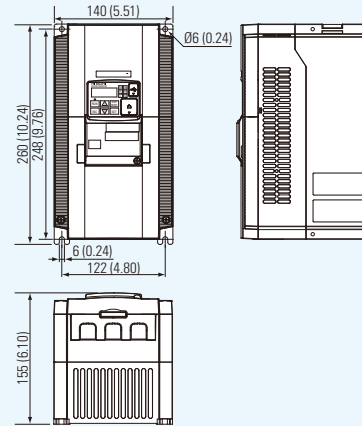

- WJ200-007MF
- WJ200-007SF-022SF
- WJ200-015LF, 022LF
- WJ200-004HF-030HF

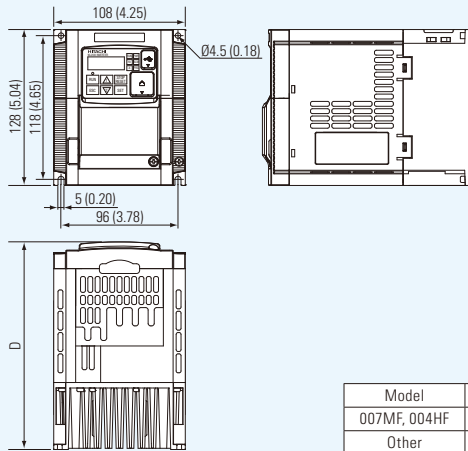

Model	D
007MF, 004HF	143.5 (5.65)
Other	170.5 (6.71)

- WJ200-110LF
- WJ200-110HF
- WJ200-150HF

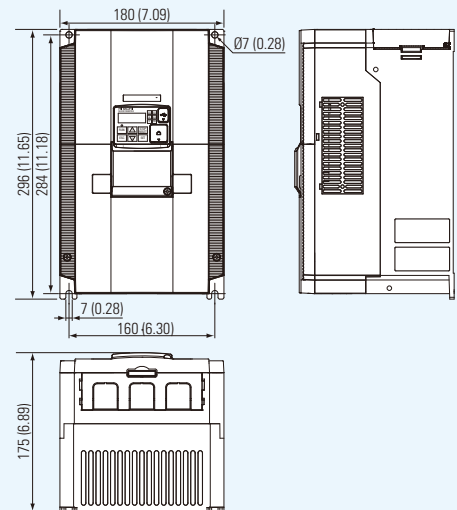

- WJ200-037LF
- WJ200-040HF

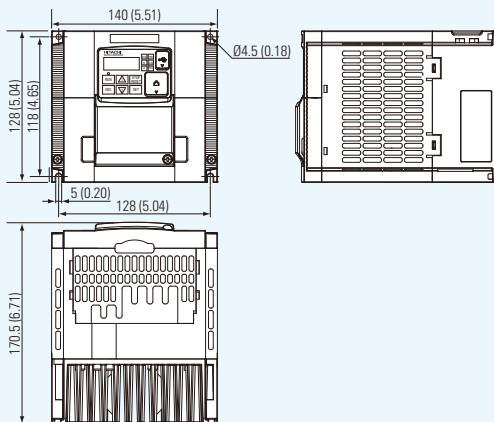

- WJ200-150LF

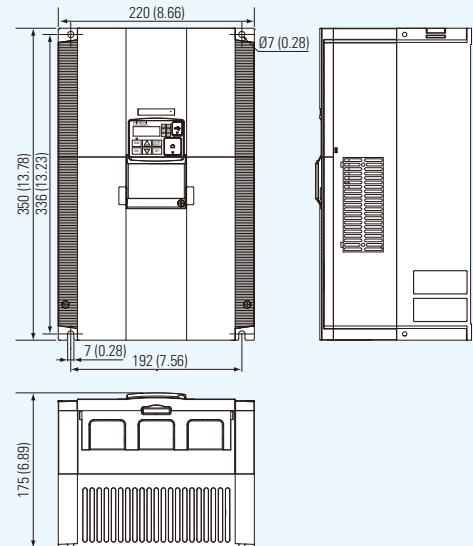



## Operation and Programming

### Operation Panel

WJ200 Series can be easily operated with the digital operator provided as standard.

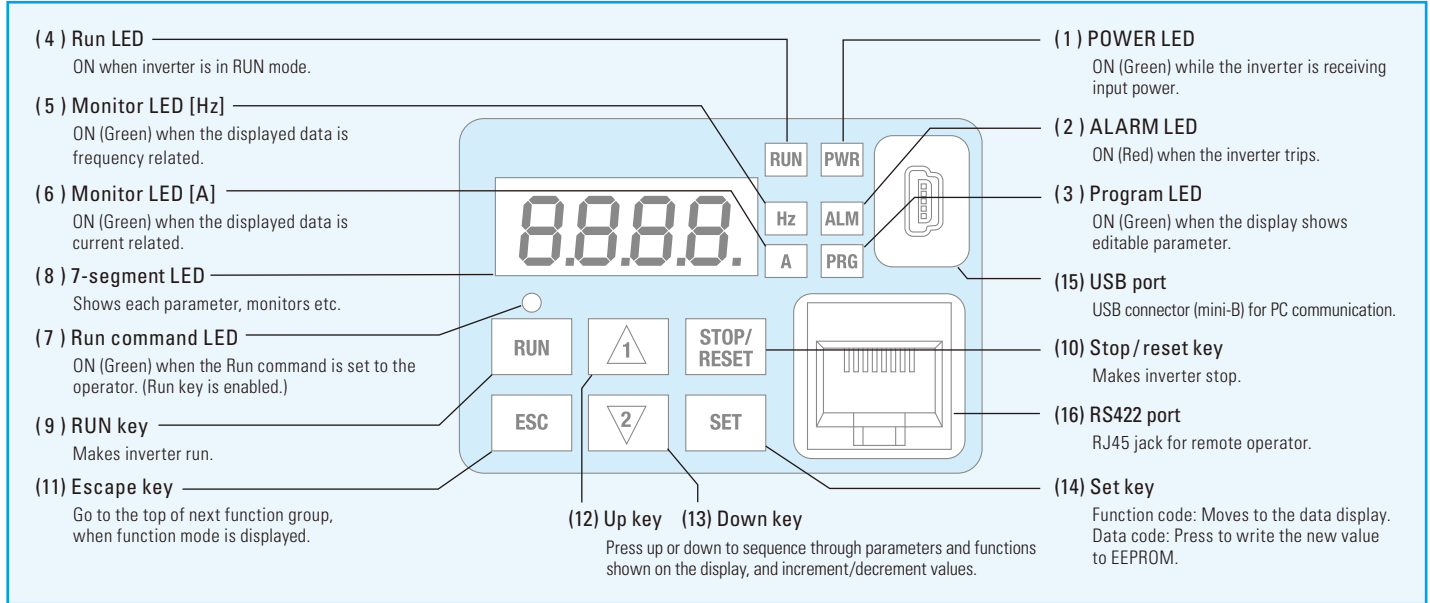

### Keypad Navigation Map

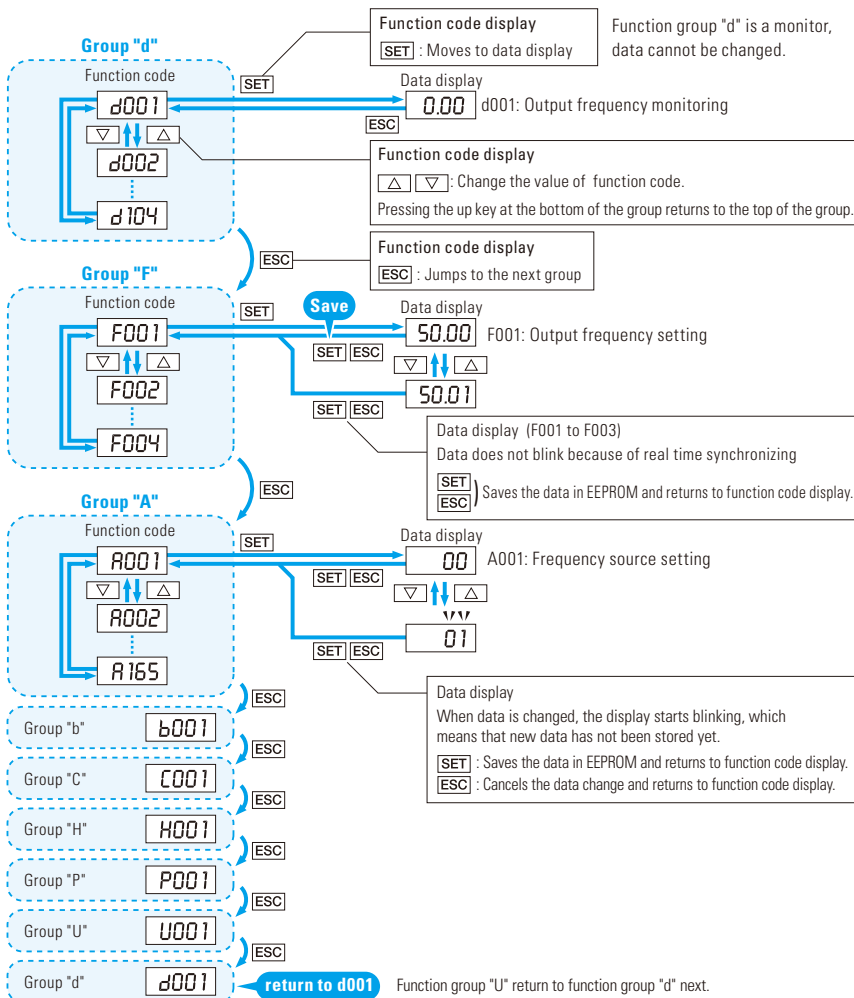

### Single-Digit Edit Mode

If a target function code or data is far from current position, using the single-digit edit mode makes it quicker to navigate there. Pressing the up key and down key at the same time brings you into the digit-by-digit navigation mode.

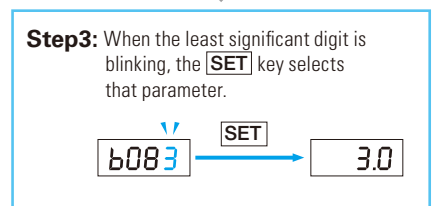
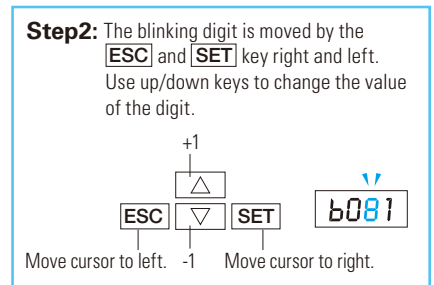
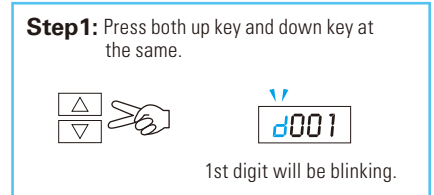

# Terminal (Arrangements/Functions)

## Terminal Description

Symbol	Terminal Name
R/L1, S/L2, T/L3	Main power supply input terminals
U/T1, V/T2, W/T3	Inverter output terminals
PD/+1, P/+	DC reactor connection terminals

Symbol	Terminal Name
P/+, RB	External braking resistor connection terminals
P/+, N/-	External braking unit connection terminals
G	Ground connection terminal

## Terminal Arrangement and Screw Diameter

Terminal	Model	Screw Diameter
	004MF 001-004SF 001-007LF	M3.5
	007MF 007-022SF 015-037LF 004-040HF	M4

Terminal	Model	Screw Diameter
	055-075LF 055-075HF	M5
	110LF 110-150HF	M6
150LF	M8	

## Terminal Arrangement of Control Circuit Terminals

Relay contacts: AL2, AL1, AL0

RS-485 comm.		Logic inputs					Logic common and power supply			
SN	7	6	5	4	3	2	1	L	PLC	P24
Short bar										
SP	EO	EA	H	O	OI	L	AM	CM2	12	11
RS-485 comm.		Pulse Train output		Pulse Train input		Analog input		Analog output		Logic outputs

## Wiring sample of control logic terminal (Sink logic)

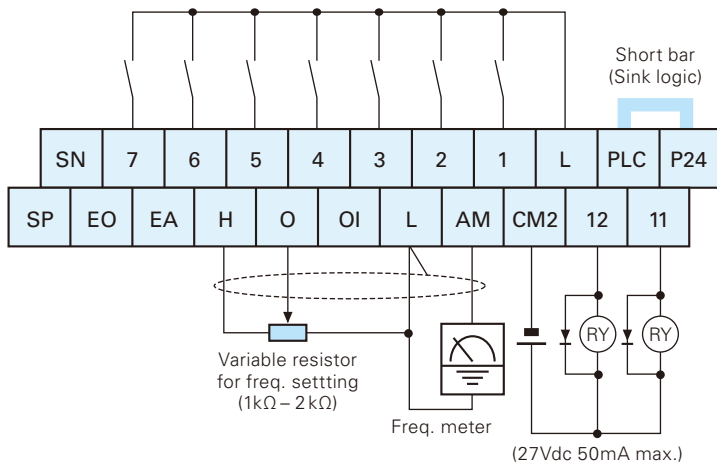

## Sink / source logic of intelligent input terminals

Sink or source logic is switched by a short bar as below.

### Sink logic

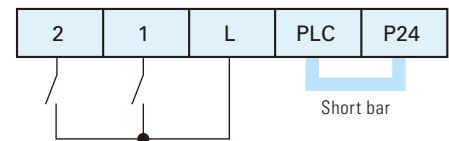

### Source logic

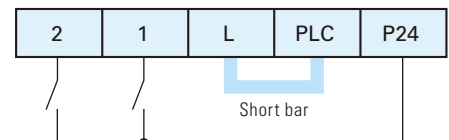

## Hardware Switches

① **Termination resistor selection switch**

OFF (Default) ON

② **Safe stop function selection switch**

Disabled (Default) Enabled

③ **EDM function selection switch**

Terminal 11 (Default) EDM output

Switch Name	Switch Name Description
① Termination resistor selection switch	Termination resistor for the RS485 communication port. WJ200 has a built-in 200Ω resistor activated by a DIP switch.
② Safe stop function selection switch	To enable the Safe stop function, set the DIP switch ON. Before operating switch, make sure that the input power supply is off.
③ EDM function selection switch	To enable the EDM function, set the DIP switch ON. Before operating switch, make sure that the input power supply is off.

## Terminal Functions

		Symbol	Terminal Name	Description / Ratings	
Analog	Power supply	L	GND for analog signals	Sum of [OI], [O], and [H] currents (return)	
		H	+10V analog reference	10VDC nominal, 10mA max.	
	Frequency setting	O	Analog voltage input	0 to 9.8 VDC range, 10 VDC nominal, input impedance 10 kΩ	
		OI	Analog current input	4 to 19.6 mA range, 20 mA nominal, input impedance 100 Ω	
	Sensor input	5/PTC	Motor thermistor input	Connect motor thermistor between PTC and L terminal to detect the motor temperature. Set 19 in C005	
Monitor Output	AM	Analog voltage output	0 to 10VDC 2mA max.		
Digital	Power supply	L	GND for logic inputs	Sum of input [1]–[7] currents (return)	
		P24	+24V for logic inputs	24VDC, 30mA. (do not short to terminal L)	
		PLC	Intelligent input common	Source type (connecting [P24] to [1]–[7] turns each input ON). Sink type (connecting [L] to [1]–[7] makes each input ON.)	
	Input	Contact	7	Discrete logic inputs (Terminal [3],[4],[5] and [7] have dual function. See following description and related pages for the details.)	[Input ON condition]
			6		Voltage between each terminal and PLC: 18VDC min.
			5		[Input OFF condition]
			4		Voltage between each terminal and PLC: 3VDC max.
			3		Allowable voltage between each terminal and PLC: 27VDC max. (use PLC or an external supply referenced to terminal L)
	Input	Pulse	2	4/GS2	Safe stop input GS2
			1		
	Input	Pulse	EA	Pulse train input A	32kHz max. Common is [L]
			7/EB	Pulse train input B	2kHz max. Common is [PLC]
	Output	Open collector	11/EDM	Discrete logic outputs [11] (Terminal [11] has dual function. See following description and related pages for the details.)	50mA max. ON state current, 27 VDC max. OFF state voltage Common is CM2 In case the EDM is selected, the functionality is based on ISO13849-1 4VDC max. ON state voltage depression
11 12			Discrete logic outputs [12]	50mA max. ON state current, 27 VDC max. OFF state voltage Common is CM2.	
CM2			GND for logic output	100 mA: [11], [12] current return	
Relay		AL0	Relay common contact	Maximum capacity of relays AL1–AL0: 250VAC, 2A (R load)/0.2A (L load) 30VDC, 3A (R load)/0.6A (L load)	
		AL1	Relay contact, normally open	AL2–AL0: 250VAC, 1A (R load)/0.2A (L load) 30VDC, 1A (R load)/0.2A (L load)	
		AL2	Relay contact, normally closed	Minimum capacity of relays AL1–AL0, AL2–AL0: 100VAC, 10mA / 5VDC, 100mA	
Output	Pulse	E0	Pulse train output	10VDC 2mA max. 32kHz max.	
Serial communication port		SP, SN	Serial communication terminal	For RS485 Modbus communication.	

# Function List

If a desired parameter is not displayed, check the setting of function "b037"(function code display restriction). To display all parameters, specify "00" for "b037".

[○= Allowed ×= Not permitted]

Code	Function Name	Setting Range	Setting During Operation (allowed or not)	Change During Operation (allowed or not)	Default Setting		
Monitor mode	d001	Output frequency monitoring	0.00 to 99.99 / 100.0 to 400.0 [Hz]	○	○	—	
	d002	Output current monitoring	0.0 to 655.3 [A]	—	—	—	
	d003	Rotation direction monitoring	F (Forward) / o (Stop) / r (Reverse)	—	—	—	
	d004	Process variable (PV), PID feedback monitoring	0.00 to 99.99 / 100.0 to 999.9 / 1000. to 9999. / 1000 to 9999 (10000 to 99990) / 1100 to 9999 (100000 to 999000)	—	—	—	
	d005	Intelligent input terminal status	(Example) 7, 5, 3, 1: ON 6, 4, 2: OFF	—	—	—	
	d006	Intelligent output terminal status	(Example) 11: ON AL, 12: OFF	—	—	—	
	d007	Scaled output frequency monitoring	0.00 to 99.99 / 100.0 to 999.9 / 1000. to 9999. / 1000 to 3999	○	○	—	
	d008	Actual-frequency monitoring	-400. to -100. / -99.9 to -10.0 / -9.99 to -0.00 / 0.00 to 99.99 / 100.0 to 400.0 [Hz]	—	—	—	
	d009	Torque command monitoring	-200 to +200 [%]	—	—	—	
	d010	Torque bias monitoring	-200 to +200 [%]	—	—	—	
	d012	Torque monitoring	-200 to +200 [%]	—	—	—	
	d013	Output voltage monitoring	0.0 to 600.0 [V]	—	—	—	
	d014	Power monitoring	0.0 to 999.9 [kW]	—	—	—	
	d015	Cumulative power monitoring	0.0 to 999.9 / 1000. to 9999. / 1000 to 9999 (10000 to 99990) / 1100 to 9999 (100000 to 999000)	—	—	—	
	d016	Cumulative operation RUN time monitoring	0. to 9999. / 1000 to 9999 (10000 to 99990) / 1100 to 9999 (100000 to 999000) [hr]	—	—	—	
	d017	Cumulative power-on time monitoring	0. to 9999. / 1000 to 9999 (10000 to 99990) / 1100 to 9999 (100000 to 999000) [hr]	—	—	—	
	d018	Heat sink temperature monitoring	-20.0 to 150.0 [°C]	—	—	—	
	d022	Life-check monitoring	1: Capacitor on main circuit board 2: cooling-fan	—	—	—	
	d023	EzSQ program counter	0 to 1024	—	—	—	
	d024	EzSQ program number	0000 to 9999	—	—	—	
	d025	User monitor 1	-2147483647 to 2147483647	—	—	—	
	d026	User monitor 2	-2147483647 to 2147483647	—	—	—	
	d027	User monitor 3	-2147483647 to 2147483647	—	—	—	
	d029	Position setting monitor	-268435455 to 268435455	—	—	—	
	d030	Position feedback monitor	-268435455 to 268435455	—	—	—	
	d050	Dual monitor	Displays two different data configured in b160 and b161.	—	—	—	
	d060	Inverter mode monitor	Displays currently selected inverter mode: I-C / I-V	—	—	—	
	d080	Trip Counter	0 to 65535	—	—	—	
d081-d086	Trip info. 1-6 (factor)	Factor code	—	—	—		
d090	Warning monitor	Warning code	—	—	—		
d102	DC voltage monitoring (across P and N)	0.0 to 999.9 / 1000. [V]	—	—	—		
d103	BRD load factor monitoring	0.0 to 100.0 [%]	—	—	—		
d104	Electronic thermal overload monitoring	0.0 to 100.0 [%]	—	—	—		
Setting mode	F001	Output frequency setting	0 / "start frequency" to "maximum frequency" [Hz]	○	○	0.00	
	F002	Acceleration (1) time setting	0.01 to 99.99 / 100.0 to 999.9 / 1000. to 3600. [s]	○	○	10.00	
	F202	Acceleration (1) time setting, 2nd motor	0.01 to 99.99 / 100.0 to 999.9 / 1000. to 3600. [s]	○	○	10.00	
	F003	Deceleration (1) time setting	0.01 to 99.99 / 100.0 to 999.9 / 1000. to 3600. [s]	○	○	10.00	
	F203	Deceleration (1) time setting, 2nd motor	0.01 to 99.99 / 100.0 to 999.9 / 1000. to 3600. [s]	○	○	10.00	
	F004	Keypad Run key routing	00 (Forward) / 01 (Reverse)	×	×	00	
	Basic settings	A001	Frequency source setting	00 (keypad potentiometer) / 01 (control circuit terminal block) / 02 (digital operator) / 03 (Modbus) / 04 (option) / 06 (pulse train input) / 07 (easy sequence) / 10 (operation function result)	×	×	02
		A201	Frequency source setting, 2nd motor		×	×	02
A002		Run command source setting	01 (control circuit terminal block) / 02 (digital operator) / 03 (Modbus) / 04 (option)	×	×	02	
A202		Run command source setting, 2nd motor		×	×	02	
A003		Base frequency setting	30.0 to "maximum frequency (1st)" [Hz]	×	×	60	
A203		Base frequency setting, 2nd motor	30.0 to "maximum frequency (2nd)" [Hz]	×	×	60	
A004		Maximum frequency setting	"Base frequency (1st)" to 400.0 [Hz]	×	×	60	
A204		Maximum frequency setting, 2nd motor		×	×	60	
Analog input setting	A005	[AT] selection	00 (switching between O and OI terminals) / 02 (switching between O terminal and keypad potentiometer) / 03 (switching between OI terminal and keypad potentiometer)	×	×	00	
	A011	Pot./O-L input active range start frequency	0.00 to 99.99 / 100.0 to 400.0 [Hz]	×	○	0.00	
	A012	Pot./O-L input active range end frequency	0.00 to 99.99 / 100.0 to 400.0 [Hz]	×	○	0.00	
	A013	Pot./O-L input active range start voltage	0 to 100 [%]	×	○	0	
	A014	Pot./O-L input active range end voltage	0 to 100 [%]	×	○	100	
	A015	Pot./O-L input start frequency enable	00 (A011) / 01 (0Hz)	×	○	01	
	A016	External frequency filter time constant	1 to 30 / 31	×	○	8	
A017	Easy sequence function selection	00 (disabled) / 01 (PRG terminal) / 02 (Always)	○	○	00		

[○= Allowed ×= Not permitted]

Code	Function Name	Setting Range	Setting During Operation (allowed or not)	Change During Operation (allowed or not)	Default Setting	
<b>Multispeed and Jogging frequency setting</b>	<b>A019</b>	Multi-speed operation selection	00 (Binary mode) / 01 (Bit mode)	×	×	00
	<b>A020</b>	Multi-speed 0 setting	0.00 / "start frequency" to "maximum frequency (1st)" [Hz]	○	○	0.00
	<b>A220</b>	Multi-speed 0 setting, 2nd motor	0.00 / "start frequency" to "maximum frequency (2nd)" [Hz]	○	○	0.00
	<b>A021 – A035</b>	Multi-speed 1 – 15 setting	0.00 / "start frequency" to "maximum frequency" [Hz]	○	○	0.00
	<b>A038</b>	Jog frequency setting	"start frequency" to 9.99 [Hz]	○	○	6.00
<b>A039</b>	Jog stop mode	00 (Free-run stop [invalid during run]) / 01 (Controlled deceleration [invalid during run]) / 02 (DC braking to stop [invalid during run]) / 03 (Free-run stop [valid during run]) / 04 (Controlled deceleration [valid during run]) / 05 (DC braking to stop [valid during run])	×	○	04	
<b>V/f Characteristic</b>	<b>A041</b>	Torque boost select	00 (manual torque boost) / 01 (automatic torque boost)	×	×	00
	<b>A241</b>	Torque boost select, 2nd motor	01 (automatic torque boost)	×	×	00
	<b>A042</b>	Manual torque boost value	0.0 to 20.0 [%]	○	○	1.0
	<b>A242</b>	Manual torque boost value, 2nd motor	0.0 to 20.0 [%]	○	○	1.0
	<b>A043</b>	Manual torque boost frequency adjustment	0.0 to 50.0 [%]	○	○	5.0
	<b>A243</b>	Manual torque boost frequency adjustment, 2nd motor	0.0 to 50.0 [%]	○	○	5.0
	<b>A044</b>	V/f characteristic curve selection	00 (VC) / 01 (VP) / 02 (free V/f) / 03 (SLV)	×	×	00
	<b>A244</b>	V/f characteristic curve selection, 2nd motor	00 (VC) / 01 (VP) / 02 (free V/f) / 03 (SLV)	×	×	00
	<b>A045</b>	V/f gain setting	20 to 100 [%]	○	○	100
	<b>A245</b>	V/f gain setting, 2nd motor	20 to 100 [%]	○	○	100
	<b>A046</b>	Voltage compensation gain for automatic torque boost	0 to 255	○	○	100
	<b>A246</b>	Voltage compensation gain for automatic torque boost, 2nd motor	0 to 255	○	○	100
	<b>A047</b>	Slip compensation gain for automatic torque boost	0 to 255	○	○	100
	<b>A247</b>	Slip compensation gain for automatic torque boost, 2nd motor	0 to 255	○	○	100
<b>DC braking</b>	<b>A051</b>	DC braking enable	00 (disabled) / 01 (enabled) / 02 (output freq < {A052})	×	○	00
	<b>A052</b>	DC braking frequency setting	0.00 to 60.00 [Hz]	×	○	0.50
	<b>A053</b>	DC braking wait time	0.0 to 5.0 [s]	×	○	0.0
	<b>A054</b>	DC braking force for deceleration	0 to 100 / 70 [%] (CT / VT)	×	○	50
	<b>A055</b>	DC braking time for deceleration	0.0 to 60.0 [s]	×	○	0.5
	<b>A056</b>	DC braking / edge or level detection for [DB] input	00 (edge operation) / 01 (level operation)	×	○	01
	<b>A057</b>	DC braking force at start	0 to 100 / 70 [%] (CT / VT)	×	○	0
	<b>A058</b>	DC braking time at start	0.0 to 60.0 [s]	×	○	0.0
	<b>A059</b>	Carrier frequency during DC braking	2.0 to 15.0 / 10.0 [kHz] (CT / VT)	×	○	5.0
<b>Frequency upper/lower limit and Jump frequency</b>	<b>A061</b>	Frequency upper limit setting	0.00 / A062 to A004 [Hz]	×	○	0.00
	<b>A261</b>	Frequency upper limit setting, 2nd motor	0.00 / A262 to A204 [Hz]	×	○	0.00
	<b>A062</b>	Frequency lower limit setting	0.00 / b082 to A061 [Hz]	×	○	0.00
	<b>A262</b>	Frequency lower limit setting, 2nd motor	0.00 / b082 to A261 [Hz]	×	○	0.00
	<b>A063</b>	Jump (center) frequency setting 1	0.00 to 99.99 / 100.0 to 400.0 [Hz]	×	○	0.00
	<b>A064</b>	Jump (hysteresis) frequency width setting 1	0.00 to 10.00 [Hz]	×	○	0.50
	<b>A065</b>	Jump (center) frequency setting 2	0.00 to 99.99 / 100.0 to 400.0 [Hz]	×	○	0.00
	<b>A066</b>	Jump (hysteresis) frequency width setting 2	0.00 to 10.00 [Hz]	×	○	0.50
	<b>A067</b>	Jump (center) frequency setting 3	0.00 to 99.99 / 100.0 to 400.0 [Hz]	×	○	0.00
	<b>A068</b>	Jump (hysteresis) frequency width setting 3	0.00 to 10.00 [Hz]	×	○	0.50
<b>PID control</b>	<b>A069</b>	Acceleration stop frequency setting	0.00 to 99.99 / 100.0 to 400.0 [Hz]	×	○	0.00
	<b>A070</b>	Acceleration stop time setting	0.0 to 60.0 [s]	×	○	0.0
	<b>A071</b>	PID enable	00 (disabled) / 01 (enabled) / 02 (enabled inverted-data output)	×	○	00
	<b>A072</b>	PID proportional gain	0.00 to 25.00	○	○	1.00
	<b>A073</b>	PID integral time constant	0.0 to 999.9 / 1000. to 3600. [s]	○	○	1.0
	<b>A074</b>	PID derivative time constant	0.00 to 99.99 / 100.0 [s]	○	○	0.00
	<b>A075</b>	PV scale conversion	0.01 to 99.99	×	○	1.00
	<b>A076</b>	PV source setting	00 (input via OI) / 01 (input via OI) / 02 (external communication) / 03 (pulse train frequency input) / 10 (operation result output)	×	○	00
	<b>A077</b>	Reverse PID action	00 (OFF) / 01 (ON)	×	○	00
	<b>A078</b>	PID output limit	0.0 to 100.0 [%]	×	○	0.0
<b>AVR function</b>	<b>A079</b>	PID feed forward selection	00 (disabled) / 01 (O input) / 02 (OI input)	×	○	00
	<b>A081</b>	AVR function select	00 (always on) / 01 (always off) / 02 (off during deceleration)	×	×	02
	<b>A281</b>	AVR function select, 2nd motor	00 (always on) / 01 (always off) / 02 (off during deceleration)	×	×	02
	<b>A082</b>	AVR voltage select	200 V class : 200 / 215 / 220 / 230 / 240 (V) 400 V class : 380 / 400 / 415 / 440 / 460 / 480 (V)	×	×	200 / 400
	<b>A282</b>	AVR voltage select, 2nd motor	200 V class : 200 / 215 / 220 / 230 / 240 (V) 400 V class : 380 / 400 / 415 / 440 / 460 / 480 (V)	×	×	200 / 400
<b>A083</b>	AVR filter time constant	0.000 to 9.999 / 10.00 [s]	×	○	0.300	
<b>A084</b>	AVR deceleration gain	50 to 200 [%]	×	○	100	

# Function List

[○= Allowed ×= Not permitted]

Code	Function Name	Setting Range	Setting During Operation (allowed or not)	Change During Operation (allowed or not)	Default Setting	
Operation mode and Accel./Decel. function	A085	Operation mode selection	00 (normal operation) / 01 (energy-saving operation)	×	×	00
	A086	Energy saving mode tuning	0.0 to 100.0 [%]	○	○	50.0
	A092	Acceleration (2) time setting	0.01 to 99.99 / 100.0 to 999.9 / 1000. to 3600. [s]	○	○	10.00
	A292	Acceleration (2) time setting, 2nd motor	0.01 to 99.99 / 100.0 to 999.9 / 1000. to 3600. [s]	○	○	10.00
	A093	Deceleration (2) time setting	0.01 to 99.99 / 100.0 to 999.9 / 1000. to 3600. [s]	○	○	10.00
	A293	Deceleration (2) time setting, 2nd motor	0.01 to 99.99 / 100.0 to 999.9 / 1000. to 3600. [s]	○	○	10.00
	A094	Select method to switch to Acc2 / Dec2 profile	00 (switching by 2CH terminal) / 01 (switching by setting) / 02 (Forward and reverse)	×	×	00
	A294	Select method to switch to Acc2 / Dec2 profile, 2nd motor		×	×	00
	A095	Acc1 to Acc2 frequency transition point	0.00 to 99.99 / 100.0 to 400.0 [Hz]	×	×	0.00
	A295	Acc1 to Acc2 frequency transition point, 2nd motor	0.00 to 99.99 / 100.0 to 400.0 [Hz]	×	×	0.00
	A096	Dec1 to Dec2 frequency transition point	0.00 to 99.99 / 100.0 to 400.0 [Hz]	×	×	0.00
	A296	Dec1 to Dec2 frequency transition point, 2nd motor	0.00 to 99.99 / 100.0 to 400.0 [Hz]	×	×	0.00
Operation mode and Accel./Decel. function	A097	Acceleration curve selection	00 (linear) / 01 (S curve) / 02 (U curve) / 03 (inverted-U curve) / 04 (EL-S curve)	×	×	01
	A098	Deceleration curve selection		×	×	01
External frequency tuning	A101	[OI]-[L] input active range start frequency	0.00 to 99.99 / 100.0 to 400.0 [Hz]	×	○	0.00
	A102	[OI]-[L] input active range end frequency	0.00 to 99.99 / 100.0 to 400.0 [Hz]	×	○	0.00
	A103	[OI]-[L] input active range start current	0 to 100 [%]	×	○	20
	A104	[OI]-[L] input active range end voltage	0 to 100 [%]	×	○	100
	A105	[OI]-[L] input start frequency enable	00 (A101) / 01 (0Hz)	×	○	00
Accel./Decel. curve	A131	Acceleration curve constant setting (for S, U, Inverse U)	01 to 10	×	○	02
	A132	Deceleration curve constant setting (for S, U, Inverse U)	01 to 10	×	○	02
Operation target frequency	A141	A input select for calculate function	00 (digital operator) / 01 (keypad potentiometer) / 02 (input via O) / 03 (input via OI) / 04 (external communication) / 05 (option) / 07 (pulse train frequency input)	×	○	02
	A142	B input select for calculate function		×	○	03
	A143	Calculation symbol	00 (A141 + A142) / 01 (A141 - A142) / 02 (A141 × A142)	×	○	00
	A145	ADD frequency	0.00 to 99.99 / 100.0 to 400.0 [Hz]	×	○	0.00
	A146	ADD direction select	00 (frequency command + A145) / 01 (frequency command - A145)	×	○	00
Acceleration and deceleration	A150	Curvature of EL-S-curve at the start of acceleration	0 to 50 [%]	×	×	10
	A151	Curvature of EL-S-curve at the end of acceleration	0 to 50 [%]	×	×	10
	A152	Curvature of EL-S-curve at the start of deceleration	0 to 50 [%]	×	×	10
	A153	Curvature of EL-S-curve at the end of deceleration	0 to 50 [%]	×	×	10
Others	A154	Deceleration stop frequency setting	0.00 to 99.99 / 100.0 to 400.0 [Hz]	×	○	0.00
	A155	Deceleration stop time setting	0.0 to 60.0 [s]	×	○	0.0
PID control	A156	PID sleep function action threshold	0.00 to 99.99 / 100.0 to 400.0 [Hz]	×	○	0.00
	A157	PID sleep function action delay time	0.0 to 25.5 [s]	×	○	0.0
Frequency trimming	A161	[VR] input active range start frequency	0.00 to 99.99 / 100.0 to 400.0 [Hz]	×	○	0.00
	A162	[VR] input active range end frequency	0.00 to 99.99 / 100.0 to 400.0 [Hz]	×	○	0.00
	A163	[VR] input active range start current	0 to 100 [%]	×	○	0
	A164	[VR] input active range end voltage	0 to 100 [%]	×	○	100
	A165	[VR] input start frequency enable	00 (A161) / 01 (0Hz)	×	○	01
Restart after instantaneous power failure	b001	Selection of automatic restart mode	00 (tripping) / 01 (starting with 0 Hz) / 02 (starting with matching frequency) / 03 (tripping after deceleration and stopping with matching frequency) / 04 (restarting with active matching frequency)	×	○	00
	b002	Allowable under-voltage power failure time	0.3 to 25.0 [s]	×	○	1.0
	b003	Retry wait time before motor restart	0.3 to 100.0 [s]	×	○	1.0
	b004	Instantaneous power failure / under-voltage trip alarm enable	00 (disabled) / 01 (enabled) / 02 (disabled during stopping and decelerating to stop)	×	○	00
	b005	Number of restarts on power failure / under-voltage trip events	00 (16 times) / 01 (unlimited)	×	○	00
	b007	Restart frequency threshold	0.00 to 99.99 / 100.0 to 400.0 [Hz]	×	○	0.00
	b008	Selection of retry after tripping	00 (tripping) / 01 (starting with 0 Hz) / 02 (starting with matching frequency) / 03 (tripping after deceleration and stopping with matching frequency) / 04 (restarting with active matching frequency)	×	○	00
	b010	Selection of retry count after undervoltage	1 to 3 [times]	×	○	3
Electronic Thermal	b011	Start freq. to be used in case of freq. matching restart	0.3 to 100.0 [s]	×	○	1.0
	b012	Level of electronic thermal setting	Set a level between 20% and 100% for the rated inverter current [A]	×	○	Rated current of inverter
	b212	Level of electronic thermal setting, 2nd motor	Set a level between 20% and 100% for the rated inverter current [A]	×	○	Rated current of inverter
	b013	Electronic thermal characteristic	00 (reduced-torque characteristic) / 01 (constant-torque characteristic) / 02 (free setting)	×	○	01
	b213	Electronic thermal characteristic, 2nd motor		×	○	01
	b015	Free setting, electronic thermal frequency (1)	0 to "electronic thermal frequency (2)" [Hz]	×	○	0
	b016	Free setting, electronic thermal current (1)	Range is 0 to inverter rated current Amps [A]	×	○	0.00
	b017	Free setting, electronic thermal frequency (2)	"electronic thermal frequency (1)" to "electronic thermal frequency (3)" [Hz]	×	○	0
	b018	Free setting, electronic thermal current (2)	Range is 0 to inverter rated current Amps [A]	×	○	0.00
	b019	Free setting, electronic thermal frequency (3)	"electronic thermal frequency (2)" to 400 [Hz]	×	○	0
b020	Free setting, electronic thermal current (3)	Range is 0 to inverter rated current Amps [A]	×	○	0.00	

[○= Allowed ×= Not permitted]

Code	Function Name	Setting Range	Setting During Operation (allowed or not)	Change During Operation (allowed or not)	Default Setting	
Overload restriction	<b>b021</b>	Overload restriction operation mode	00 (disabled) / 01 (enabled during acceleration and constant-speed operation) / 02 (enabled during constant-speed operation) / 03 (enabled during acceleration and constant-speed operation [speed increase at regeneration])	×	○	01
	<b>b221</b>	Overload restriction operation mode, 2nd motor		×	○	01
	<b>b022</b>	Overload restriction level setting	Set a level between 20% and 200% / 150% for the rated inverter current [A] (CT / VT)	×	○	150% of Rated current
	<b>b222</b>	Overload restriction level setting, 2nd motor		×	○	
	<b>b023</b>	Deceleration rate at overload restriction	0.1 to 999.9 / 1000. to 3000. [s]	×	○	1.0
	<b>b223</b>	Overload restriction operation mode, 2nd motor	0.1 to 999.9 / 1000. to 3000. [s]	×	○	1.0
	<b>b024</b>	Overload restriction operation mode 2	00 (disabled) / 01 (enabled during acceleration and constant-speed operation) / 02 (enabled during constant-speed operation) / 03 (enabled during acceleration and constant-speed operation [speed increase at regeneration])	×	○	01
	<b>b025</b>	Overload restriction level 2 setting	Set a level between 20% and 200% / 150% for the rated inverter current [A] (CT / VT)	×	○	150% of Rated current
	<b>b026</b>	Deceleration rate 2 at overload restriction	0.1 to 999.9 / 1000. to 3000. [s]	×	○	1.0
	<b>b027</b>	OC suppression selection	00 (disabled) / 01 (enabled)	×	○	01
	<b>b028</b>	Current level of active freq. matching restart setting	Set a level between 20% and 200% / 150% for the rated inverter current [A] (CT / VT)	×	○	Rated current of inverter
	<b>b029</b>	Deceleration rate of frequency matching restart setting	0.1 to 999.9 / 1000. to 3000. [s]	×	○	0.5
<b>b030</b>	Start freq. to be used in case of active freq. Matching restart	00 (frequency at the last shutoff) / 01 (maximum frequency) / 02 (set frequency)	×	○	00	
Lock	<b>b031</b>	Software lock mode selection	00 (all parameters except b031 are locked when [SFT] terminal is ON) / 01 (all parameters except b031 and output frequency F001 are locked when [SFT] terminal is ON) / 02 (all parameters except b031 are locked) / 03 (all parameters except b031 and output frequency F001 are locked) / 10 (High level access including b031)	×	○	01
Others	<b>b033</b>	Motor cable length parameter	5 to 20	○	○	10
	<b>b034</b>	Run / power ON warning time	0 to 9999. (0 to 99990 [hr]) / 1000 to 6553 (100000 to 655350 [hr])	×	○	0
	<b>b035</b>	Rotation direction restriction	00 (Enable for both dir) / 01 (Enable for forward only) / 02 (Enable for reverse only)	×	×	00
	<b>b036</b>	Reduced voltage start selection	0 (minimum reduced voltage start time) to 255 (maximum reduced voltage start time)	×	○	2
	<b>b037</b>	Function code display restriction	0 (full display) / 1 (function-specific display) / 2 (user setting) / 3 (data comparison display) / 4 (basic display) / 5 (monitor display)	×	○	04
	<b>b038</b>	Initial-screen selection	000 (Func. code that SET key pressed last displayed) / 001 to 060 (d001 to d060) / 201 (F001) / 202 (Screen displayed when the STR key was pressed last)	×	○	001
	<b>b039</b>	Automatic user parameter setting	00 (disabled) / 01 (enabled)	×	○	00
Torque limit	<b>b040</b>	Torque limit selection	00 (quadrant-specific setting) / 01 (switching by terminal) / 02 (0 input)	×	○	00
	<b>b041–b044</b>	Torque limit (1)–(4)	0 to 200 [%] / no	×	○	200
	<b>b045</b>	Torque LAD STOP selection	00 (disabled) / 01 (enabled)	×	○	00
	<b>b046</b>	Reverse run protection	00 (disabled) / 01 (enabled)	×	○	01
Others	<b>b049</b>	Dual Rating Selection	00 (CT mode) / 01 (VT mode) [1-phase 100V class is only with CT]	×	×	00
Nonstop operation at momentary power failure	<b>b050</b>	Selection of the nonstop operation	00 (disabled) / 01 (enabled) / 02 (nonstop operation at momentary power failure [no restoration]) / 03 (nonstop operation at momentary power failure [restoration to be done])	×	×	00
	<b>b051</b>	Nonstop operation start voltage setting	0.0 to 999.9 / 1000. [V]	×	×	220 / 440
	<b>b052</b>	OV-LAD Stop level of nonstop operation setting	0.0 to 999.9 / 1000. [V]	×	×	360 / 720
	<b>b053</b>	Deceleration time of nonstop operation setting	0.1 to 999.9 / 1000. to 3600. [s]	×	×	1.00
	<b>b054</b>	Frequency width of quick deceleration setting	0.00 to 10.00 [Hz]	×	×	0.00
Window comparator	<b>b060</b>	Maximum-limit level of window comparators O	0 to 100 [%]	○	○	100
	<b>b061</b>	Minimum-limit level of window comparators O	0 to 100 [%]	○	○	0
	<b>b062</b>	Hysteresis width of window comparators O	0 to 10 [%]	○	○	0
	<b>b063</b>	Maximum-limit level of window comparators OI	0 to 100 [%]	○	○	100
	<b>b064</b>	Minimum-limit level of window comparators OI	0 to 100 [%]	○	○	0
	<b>b065</b>	Hysteresis width of window comparator (OI)	0 to 10 [%]	○	○	0
Others	<b>b070</b>	Operation level at O disconnection	0 to 100 [%] / no	×	○	no
	<b>b071</b>	Operation level at OI disconnection	0 to 100 [%] / no	×	○	no
	<b>b075</b>	Ambient temperature	-10 to 50 [°C]	○	○	40
	<b>b078</b>	Watt-hour reset	00 (OFF) / 01 (ON)	○	○	00
	<b>b079</b>	Watt-hour display gain setting	1 to 1000	○	○	1
	<b>b082</b>	Start frequency adjustment	0.10 to 9.99 [Hz] (to 200Hz)	×	○	0.50
	<b>b083</b>	Carrier frequency setting	2.0 to 15.0 [kHz]	×	○	2.0
	<b>b084</b>	Initialization mode (parameters or trip history)	00 (disabled) / 01 (clearing the trip history) / 02 (initializing the data) / 03 (clearing the trip history and initializing the data) / 04 (clearing the trip history and initializing the data and EzSQ program)	×	×	00
	<b>b085</b>	Country for initialization	00 / 01	×	×	00
	<b>b086</b>	Frequency scaling conversion factor	0.01 to 99.99	○	○	1.00
<b>b087</b>	STOP key enable	00 (enabled) / 01 (disabled) / 02 (disabled only stop)	×	○	00	

# Function List

[○= Allowed ×= Not permitted]

Code	Function Name	Setting Range	Setting During Operation (allowed or not)	Change During Operation (allowed or not)	Default Setting	
Others	<b>b088</b>	Restart mode after FRS	00 (starting with 0 Hz) / 01 (starting with matching frequency) / 02 (starting with active matching frequency)	×	○	00
	<b>b089</b>	Automatic carrier frequency reduction	00 (disabled) / 01 (enabled [output current controlled]) / 02 (enabled [fin temperature controlled])	×	×	01
	<b>b090</b>	Dynamic braking usage ratio	0.0 to 100.0 [%]	×	○	0.0
	<b>b091</b>	Stop mode selection	00 (deceleration until stop) / 01 (free-run stop)	×	○	00
	<b>b092</b>	Cooling fan control	00 (fan always ON) / 01 (ON fan only during inverter operation [including 5 minutes after power-on and power-off]) / 02 (fan temperature controlled)	×	○	01
	<b>b093</b>	Accumulated time clear of the cooling fan	00 (count) / 01 (clear)	×	×	00
	<b>b094</b>	Initialization target data setting	00 (All parameters) / 01 (All parameters except in/output terminals and communication) / 02 (Uxxx) / 03 (expect Uxxx)	×	×	00
	<b>b095</b>	Dynamic braking control (BRD) selection	00 (disabled) / 01 (enabled [disabled while the inverter is stopped]) / 02 (enabled [enabled also while the inverter is stopped])	×	○	01
	<b>b096</b>	BRD activation level	330 to 380 / 660 to 760 [V]	×	○	360 / 720
<b>b097</b>	BRD register	Set range : minimum connectable register Rbmin to 600.0 [Ω]	×	○	Min. resistance	
Free-setting V / f pattern	<b>b100</b>	Free-setting V / F freq. (1)	0. to b102 [Hz]	×	×	0.
	<b>b101</b>	Free-setting V / F volt. (1)	0.0 to 800.0 [V]	×	×	0.0
	<b>b102</b>	Free-setting V / F freq. (2)	0. to b104 [Hz]	×	×	0.
	<b>b103</b>	Free-setting V / F volt. (2)	0.0 to 800.0 [V]	×	×	0.0
	<b>b104</b>	Free-setting V / F freq. (3)	0. to b106 [Hz]	×	×	0.
	<b>b105</b>	Free-setting V / F volt. (3)	0.0 to 800.0 [V]	×	×	0.0
	<b>b106</b>	Free-setting V / F freq. (4)	0. to b108 [Hz]	×	×	0.
	<b>b107</b>	Free-setting V / F volt. (4)	0.0 to 800.0 [V]	×	×	0.0
	<b>b108</b>	Free-setting V / F freq. (5)	0. to b110 [Hz]	×	×	0.
	<b>b109</b>	Free-setting V / F volt. (5)	0.0 to 800.0 [V]	×	×	0.0
	<b>b110</b>	Free-setting V / F freq. (6)	0. to b112 [Hz]	×	×	0.
	<b>b111</b>	Free-setting V / F volt. (6)	0.0 to 800.0 [V]	×	×	0.0
	<b>b112</b>	Free-setting V / F freq. (7)	0. to 400 (to 1000) [Hz]	×	×	0.
<b>b113</b>	Free-setting V / F volt. (7)	0.0 to 800.0 [V]	×	×	0.0	
Others	<b>b120</b>	Brake control enable	00 (disabled) / 01 (enabled)	×	○	00
	<b>b121</b>	Brake Wait Time for Release	0.00 to 5.00 [s]	×	○	0.00
	<b>b122</b>	Brake Wait Time for Acceleration	0.00 to 5.00 [s]	×	○	0.00
	<b>b123</b>	Brake Wait Time for Stopping	0.00 to 5.00 [s]	×	○	0.00
	<b>b124</b>	Brake Wait Time for Confirmation	0.00 to 5.00 [s]	×	○	0.00
	<b>b125</b>	Brake release freq. setting	0.00 to 99.99 / 100.0 to 400.0 [Hz]	×	○	0.00
	<b>b126</b>	Brake release current setting	Set range: 0 to 200% of inverter rated current [A]	×	○	Rated current of inverter
	<b>b127</b>	Braking frequency	0.00 to 99.99 / 100.0 to 400.0 [Hz]	×	○	0.00
	<b>b130</b>	Over-voltage LADSTOP enable	00 (disabled) / 01 (enabled) / 02 (enabled with acceleration)	×	○	00
	<b>b131</b>	Over-voltage LADSTOP level	330 to 395 / 660 to 790 [V]	×	○	380 / 760
	<b>b132</b>	DC bus AVR constant setting	0.10 to 30.00 [s]	×	○	1.00
	<b>b133</b>	DC bus AVR for decel. Proportional-gain	0.00 to 5.00	○	○	0.20
	<b>b134</b>	DC bus AVR for decel. Integral-time	0.0 to 150.0 [s]	○	○	1.0
	<b>b145</b>	GS input performance selection	00 (non Trip) / 01 (Trip)	×	○	00
	<b>b150</b>	Panel Display selection	d001 to d060	○	○	001
	<b>b160</b>	1st parameter of Double Monitor	d001 to d030	○	○	001
	<b>b161</b>	2nd parameter of Double Monitor	d001 to d030	○	○	002
	<b>b163</b>	Data change mode selection of d001 and d007	00 (disabled) / 01 (enabled)	○	○	00
	<b>b164</b>	Automatic return to the initial display	00 (disabled) / 01 (enabled)	○	○	00
<b>b165</b>	Action selection in case of external operator disconnection	00 (tripping) / 01 (tripping after decelerating and stopping the motor) / 02 (ignoring errors) / 03 (stopping the motor after free-running) / 04 (decelerating and stopping the motor)	○	○	02	
<b>b166</b>	Data Read / Write selection	00 (read / write enable) / 01 (both read, write disable)	×	○	00	
<b>b171</b>	Inverter mode selection	00 (disabled) / 01 (IM enabled)	×	×	00	
<b>b180</b>	Initialization trigger	00 (disabled) / 01 (enabled)	×	×	00	
Password	<b>b190</b>	Password A setting	0 (disabled) / 0001 to FFFF (enabled)	×	×	0000
	<b>b191</b>	Password A for authentication	0000 to FFFF	×	×	0000
	<b>b192</b>	Password B setting	0 (disabled) / 0001 to FFFF (enabled)	×	×	0000
	<b>b193</b>	Password B for authentication	0000 to FFFF	×	×	0000



[○= Allowed ×= Not permitted]

Code	Function Name	Setting Range	Setting During Operation (allowed or not)	Change During Operation (allowed or not)	Default Setting	
Intelligent input terminal setting	C001	Terminal [1] function	00 (FW: Forward Run) / 01 (RV: Reverse RUN) / 02 (CF1: Multispeed 1setting) / 03 (CF2: Multispeed 2 setting) / 04 (CF3: Multispeed 3 setting) / 05 (CF4: Multispeed 4 setting) / 06 (JG: Jogging) / 07 (DB: external DC braking) / 08 (SET: Set 2nd motor data) / 09 (2CH: 2-stage acceleration/deceleration) / 11 (FRS: free-run stop) / 12 (EXT: external trip) / 13 (USP: unattended startprotection) / 14 (CS: commercial power source enable) / 15 (SFT: software lock) / 16 (AT: analoginput voltage/current select) / 18 (RS: reset) / 19 (PTC (only C005): Thermistor input) / 20 (STA: starting by 3-wire input) / 21 (STP: stopping by 3-wire input) / 22 (F/R: forward/reverse switching by 3-wire input) / 23 (PID: PID disable) / 24 (PIDC: PID reset) / 27 (UP: remote control UP function) / 28 (DWN: remote control DOWN function) / 29 (UDC: remote control data clearing) / 31 (OPE: forcible operation) / 32 (SF1: multispeed bit 1) / 33 (SF2: multispeed bit 2) / 34 (SF3: multispeed bit 3) / 35 (SF4: multispeed bit 4) / 36 (SF5: multispeed bit 5) / 37 (SF6: multispeed bit 6) / 38 (SF7: multispeed bit 7) / 39 (OLR: overload restriction selection) / 40 (TL:torque limit enable) / 41 (TRQ1: torque limit selectionbit 1) / 42 (TRQ2: torque limit selection bit 2) / 44 (BOK: braking confirmation) / 46 (LAC: LAD cancellation) / 47 (PCLR: clearance of position deviation) / 50 (ADD: trigger for frequency addition[A145]) / 51 (F-TM: forcible-terminal operation) / 52 (ATR: permission of torque command input) / 53 (KHC: cumulative power clearance) / 56 (MI1: general-purpose input 1) / 57 (MI2: general-purpose input 2) / 58 (MI3: general-purpose input 3) / 59 (MI4: general-purpose input 4) / 60 (MI5: general-purpose input 5) / 61 (MI6: general-purpose input 6) / 62 (MI7: general-purpose input 7) / 65 (AHD: analog command holding) / 66 (CP1: multistage position settings selection 1) / 67 (CP2: multistage position settings selection 2) / 68 (CP3: multistage position settings selection 3) / 69 (ORL: Zero-return limit function) / 70 (ORG: Zero-return trigger function) / 73 (SPD: speed / position switching) / 77 (GS1: safety input 1) / 78 (GS2: safety input 2) / 81 (485: EzCOM) / 82 (PRG: executing EzSQ program) / 83 (HLD: retain output frequency) / 84 (ROK: permission of run command) / 85 (EB: Rotation direction detection for V/f with ENC) / 86 (DISP: Display limitation) / 255 (no: no assignment)	×	○	00 (FW)
	C002	Terminal [2] function	01 (RV)	×	○	01 (RV)
	C003	Terminal [3] function	02 (CF1)	×	○	02 (CF1)
	C004	Terminal [4] function	03 (CF2)	×	○	03 (CF2)
	C005	Terminal [5] function	09 (2CH)	×	○	09 (2CH)
	C006	Terminal [6] function	18 (RS)	×	○	18 (RS)
	C007	Terminal [7] function	13 (USP)	×	○	13 (USP)
	C011 - C017	Terminal [1] - [7] active state	00 (NO) / 01 (NC)	×	○	00
Intelligent output terminal setting	C021	Terminal [11] function	00 (RUN: running) / 01 (FA1: constant-speed reached) / 02 (FA2: set frequency overreached) / 03 (OL: overload notice advance signal [1]) / 04 (OD: output deviation for PID control) / 05 (AL: alarm signal) / 06 (FA3: set frequency reached) / 07 (OTQ: over-torque) / 09 (UV: undervoltage) / 10 (TRQ: torque limited) / 11 (RNT: operation time over) / 12 (ONT: plug-in time over) / 13 (THM: thermal alarm signal) / 19 (BRK: brake release) / 20 (BER: braking error) / 21 (ZS: 0 Hz detection signal) / 22 (DSE: speed deviation maximum) / 23 (POK: positioning completed) / 24 (FA4: set frequency overreached 2) / 25 (FA5: set frequency reached 2) / 26 (DL2: overload notice advance signal [2]) / 27 (ODC: analog 0 input disconnection) / 28 (OIODC: analog 0 input disconnection) / 31 (FBV: PID feedback comparison) / 32 (NDC: communication line disconnection) / 33 (LOG1: logicaloperation result 1) / 34 (LOG2: logical operation result 2) / 35 (LOG3: logical operation result 3) / 39 (WAC: capacitor life warning) / 40 (WAF: cooling-fan) / 41 (FR: starting contact signal) / 42 (OHF: heat sink overheat warning) / 43 (LOC: low-current indication signal) / 44 (MO1: general-purpose output 1) / 45 (MO2: general-purpose output 2) / 46 (MO3: general-purpose output 3) / 50 (IRDY: inverter ready) / 51 (FWR: forward rotation) / 52 (RVR: reverse rotation) / 53 (MJA: major failure) / 54 (WCO: window comparator 0) / 55 (WCO1: window comparator 01) / 58 (FREF) / 59 (REF) / 60 (SETM) / 62 (EDM) / 63 (OPO: Option) / 255 (no: no assignment)	×	○	01 (FA1)
	C022	Terminal [12] function	00 (RUN)	×	○	00 (RUN)
	C026	Alarm relay terminal function	05 (AL)	×	○	05 (AL)
Analog monitoring	C027	EO signal selection (Pulse / PWM output)	00 (output frequency) / 01 (output current) / 02 (output torque) / 03 (digital output frequency) / 04 (output voltage) / 05 (input power) / 06 (electronic thermal overload) / 07 (LAD frequency) / 08 (digital current monitoring) / 10 (heat sink temperature) / 12 (general-purpose output YA0) / 15 (Pulse train input monitor) / 16 (option)	×	○	07
	C028	[AM] signal selection	00 (output frequency) / 01 (output current) / 02 (output torque) / 04 (output voltage) / 05 (input power) / 06 (electronic thermal overload) / 07 (LAD frequency) / 10 (heat sink temperature) / 11 (output torque [signed value]) / 13 (general-purpose output YA1) / 16 (option)	×	○	07
	C030	Digital current monitor reference value	Set a level between 20% and 200% for the rated inverter current [A]	○	○	Rated current of inverter
Intelligent output terminal setting	C031	Terminal [11] active state	00 (NO) / 01 (NC)	×	○	00
	C032	Terminal [12] active state	00 (NO) / 01 (NC)	×	○	00
	C036	Alarm relay active state	00 (NO) / 01 (NC)	×	○	01
Levels and output terminal status	C038	Output mode of low load detection signal	00 (output during acceleration/deceleration and constant-speed operation) / 01 (output only during constant-speed operation)	×	○	01
	C039	Low load detection level	Set range: 0 to 200% of inverter rated current [A]	○	○	Rated current of inverter
	C040	Output mode of overload warning	00 (output during acceleration / deceleration and constant-speed operation) / 01 (output only during constant-speed operation)	×	○	01

# Function List

Code	Function Name	Setting Range	Setting During Operation (allowed or not)	Change During Operation (allowed or not)	Default Setting	
Levels and output terminal status	C041	Overload level setting	Set range: 0 to 200% of inverter rated current [A]	○	○	115% of Rated current
	C241	Overload level setting, 2nd motor	Set range: 0 to 200% of inverter rated current [A]	○	○	115% of Rated current
	C042	Frequency arrival setting for acceleration	0.00 to 99.99 / 100.0 to 400.0 [Hz]	×	○	0.00
	C043	Frequency arrival setting for deceleration	0.00 to 99.99 / 100.0 to 400.0 [Hz]	×	○	0.00
	C044	PID deviation level setting	0.0 to 100.0 [%]	×	○	3.0
	C045	Frequency arrival signal for acceleration (2)	0.00 to 99.99 / 100.0 to 400.0 [Hz]	×	○	0.00
	C046	Frequency arrival signal for deceleration (2)	0.00 to 99.99 / 100.0 to 400.0 [Hz]	×	○	0.00
	C047	Pulse train input scale conversion for EO output	0.01 to 99.99	○	○	1.00
	C052	PID FBV function high limit	0.0 to 100.0 [%]	×	○	100.0
	C053	PID FBV function variable low limit	0.0 to 100.0 [%]	×	○	0.0
	C054	Over-torque / under-torque selection	00 (Over torque) / 01 (under torque)	×	○	00
	C055	Over / under-torque level (Forward powering mode)	0 to 200 [%]	×	○	100
	C056	Over / under-torque (Reverse regen. mode)	0 to 200 [%]	×	○	100
	C057	Over / under-torque (Reverse powering mode)	0 to 200 [%]	×	○	100
	C058	Over / under-torque level (Forward regen. mode)	0 to 200 [%]	×	○	100
	Communication function	C059	Signal output mode of Over / under torque	00 (output during acceleration / deceleration and constant-speed operation) / 01 (output only during constant-speed operation)	×	○
C061		Electronic thermal warning level setting	0 to 100 [%]	×	○	90
C063		Zero speed detection level setting	0.00 to 99.99 / 100.0 [Hz]	×	○	0.00
C064		Heat sink overheat warning	0. to 110. [°C]	×	○	100
C071		Communication speed selection	03 (2400bps) / 04 (4800bps) / 05 (9600bps) / 06 (19200bps) / 07 (38400bps) / 08 (57600bps) / 09 (76800bps) / 10 (115200bps)	×	○	05
C072		Node allocation	1 to 247	×	○	1
C074		Communication parity selection	00 (no parity) / 01 (even parity) / 02 (odd parity)	×	○	00
C075		Communication stop bit selection	1 (1bit) / 2 (2bit)	×	○	1
Adjustment	C076	Communication error select	00 (tripping) / 01 (tripping after decelerating and stopping the motor) / 02 (ignoring errors) / 03 (stopping the motor after free-running) / 04 (decelerating and stopping the motor)	×	○	02
	C077	Communication error time-out	0.00 to 99.99 [s]	×	○	0.00
	C078	Communication wait time	0 to 1000 [ms]	×	○	0
	C081	0 input span calibration	0. to 200.0 [%]	○	○	100.0
Communication function	C082	01 input span calibration	0. to 200.0 [%]	○	○	100.0
	C085	Thermistor input (PTC) span calibration	0. to 200.0 [%]	○	○	100.0
	C091	00 (Disable) / 01 (Enable)	00	○	○	00
	C096	Communication selection	00 (Modbus-RTU) / 01 (EzCOM) / 02 (EzCOM [administrator])	×	×	00
	C098	EzCOM start adr. of master	01 to 08	×	×	01
	C099	EzCOM end adr. of master	01 to 08	×	×	01
	C100	EzCOM starting trigger	00 (Input terminal) / 01 (Always)	×	×	00
	C101	UP / DWN memory mode selection	00 (not storing the frequency data) / 01 (storing the frequency data)	×	○	00
Others	C102	Reset selection	00 (resetting the trip when RS is on) / 01 (resetting the trip when RS is off) / 02 (enabled resetting only upon tripping [resetting when RS is on]) / 03 (resetting only trip)	○	○	00
	C103	Restart mode after reset	00 (starting with 0 Hz) / 01 (starting with matching frequency) / 02 (restarting with active matching frequency)	×	○	00
	C104	UP / DWN clear: terminal input mode selection	00 (0Hz) / 01 (EEPROM data when power supply is turned on)	×	○	00
	C105	EO gain adjustment	50 to 200 [%]	○	○	100
	C106	AM gain adjustment	50 to 200 [%]	○	○	100
	C109	AM bias adjustment	0 to 100 [%]	○	○	0
	C111	Overload setting (2)	Set range: 0 to 200% of inverter rated current [A]	○	○	115% of Rated current
Input / Output terminal operation function	C130	Output 11 on-delay time	0.0 to 100.0 [s]	×	○	0.0
	C131	Output 11 off-delay time	0.0 to 100.0 [s]	×	○	0.0
	C132	Output 12 on-delay time	0.0 to 100.0 [s]	×	○	0.0
	C133	Output 12 off-delay time	0.0 to 100.0 [s]	×	○	0.0
	C140	Output RY on-delay time	0.0 to 100.0 [s]	×	○	0.0
	C141	Output RY off-delay time	0.0 to 100.0 [s]	×	○	0.0
	C142	Logical output signal 1 selection 1	Same as the settings of C021 to C026 (except those of LOG1 to LOG3 & OPO, no)	×	○	00
	C143	Logical output signal 1 selection 2	Same as the settings of C021 to C026 (except those of LOG1 to LOG3 & OPO, no)	×	○	00
	C144	Logical output signal 1 operator selection	00 (AND) / 01 (OR) / 02 (XOR)	×	○	00
	C145	Logical output signal 2 selection 1	Same as the settings of C021 to C026 (except those of LOG1 to LOG3 & OPO, no)	×	○	00
	C146	Logical output signal 2 selection 2	Same as the settings of C021 to C026 (except those of LOG1 to LOG3 & OPO, no)	×	○	00
	C147	Logical output signal 2 operator selection	00 (AND) / 01 (OR) / 02 (XOR)	×	○	00
	C148	Logical output signal 3 selection 1	Same as the settings of C021 to C026 (except those of LOG1 to LOG3 & OPO, no)	×	○	00
	C149	Logical output signal 3 selection 2	Same as the settings of C021 to C026 (except those of LOG1 to LOG3 & OPO, no)	×	○	00
C150	Logical output signal 3 operator selection	00 (AND) / 01 (OR) / 02 (XOR)	×	○	00	
C160-C166	Response time of intelligent input terminal 1-7	0 to 200 (× 2ms)	×	○	1.	
C169	Multistage speed / position determination time	0. to 200. (× 10ms)	×	○	0.	

[○= Allowed ×= Not permitted]

Code	Function Name	Setting Range	Setting During Operation (allowed or not)	Change During Operation (allowed or not)	Default Setting	
Motor constants and gain setting	H001	Auto-tuning Setting	00 (disabled auto-tuning)/01 (auto-tuning without rotation)/02 (auto-tuning with rotation)	×	×	00
	H002	Motor data selection	00 (Hitachi standard data) / 02 (auto-tuned data)	×	×	00
	H202	Motor data selection, 2nd motor	00 (Hitachi standard data) / 02 (auto-tuned data)	×	×	00
	H003	Motor capacity	0.1/0.2/0.4/0.55/0.75/1.1/1.5/2.2/3.0/3.7/4.0/5.5/7.5/11.0/15.0/18.5 [kW]	×	×	Factory set
	H203	Motor capacity, 2nd motor	0.1/0.2/0.4/0.55/0.75/1.1/1.5/2.2/3.0/3.7/4.0/5.5/7.5/11.0/15.0/18.5 [kW]	×	×	Factory set
	H004	Motor poles setting	2/4/6/8/10 [pole]	×	×	4
	H204	Motor poles setting, 2nd motor	2/4/6/8/10 [pole]	×	×	4
	H005	Motor speed response constant	1 to 1000	○	○	100.
	H205	Motor speed response constant, 2nd motor	1 to 1000	○	○	100.
	H006	Motor stabilization constant	0 to 255	○	○	100.
	H206	Motor stabilization constant, 2nd motor	0 to 255	○	○	100.
	H020	Motor constant R1	0.001 to 9.999/10.00 to 65.53 [Ω]	×	×	Depending on motor capacity
	H220	Motor constant R1, 2nd motor	0.001 to 9.999/10.00 to 65.53 [Ω]	×	×	
	H021	Motor constant R2	0.001 to 9.999/10.00 to 65.53 [Ω]	×	×	
	H221	Motor constant R2, 2nd motor	0.001 to 9.999/10.00 to 65.53 [Ω]	×	×	
	H022	Motor constant L	0.01 to 99.99/100.0 to 655.3 [mH]	×	×	
	H222	Motor constant L, 2nd motor	0.01 to 99.99/100.0 to 655.3 [mH]	×	×	
	H023	Motor constant I0	0.01 to 99.99/100.0 to 655.3 [A]	×	×	
	H223	Motor constant I0, 2nd motor	0.01 to 99.99/100.0 to 655.3 [A]	×	×	
	H024	Motor constant J	0.001 to 9.999/10.00 to 99.99/100.0 to 999.9/1000. to 9999. [kgm <sup>2</sup> ]	×	×	
	H224	Motor constant J, 2nd motor	0.001 to 9.999/10.00 to 99.99/100.0 to 999.9/1000. to 9999. [kgm <sup>2</sup> ]	×	×	
	H030	Auto constant R1	0.001 to 9.999/10.00 to 65.53 [Ω]	×	×	
	H230	Auto constant R1, 2nd motor	0.001 to 9.999/10.00 to 65.53 [Ω]	×	×	
	H031	Auto constant R2	0.001 to 9.999/10.00 to 65.53 [Ω]	×	×	
	H231	Auto constant R2, 2nd motor	0.001 to 9.999/10.00 to 65.53 [Ω]	×	×	
	H032	Auto constant R1	0.01 to 99.99/100.0 to 655.3 [mH]	×	×	
	H232	Auto constant R1, 2nd motor	0.01 to 99.99/100.0 to 655.3 [mH]	×	×	
	H033	Auto constant R1	0.01 to 99.99/100.0 to 655.3 [A]	×	×	
	H233	Auto constant R1, 2nd motor	0.01 to 99.99/100.0 to 655.3 [A]	×	×	
	H034	Auto constant R1	0.001 to 9.999/10.00 to 99.99/100.0 to 999.9/1000. to 9999. [kgm <sup>2</sup> ]	×	×	
H234	Auto constant R1, 2nd motor	0.001 to 9.999/10.00 to 99.99/100.0 to 999.9/1000. to 9999. [kgm <sup>2</sup> ]	×	×		
H050	ASR P-Gain for FB control	0.00 to 10.00	○	○	0.20	
H051	ASR I-Gain for FB control	0 to 1000	○	○	2	
PM motor control	H102	PM motor code setting	00 (Hitachi standard data) / 01 (auto-tuned data)	×	×	00
	H103	PM motor capacity	0.1/0.2/0.4/0.55/0.75/1.1/1.5/2.2/3.0/3.7/4.0/5.5/7.5/11.0/15.0/18.5 [kW]	×	×	Depending on motor capacity
	H104	PM motor poles setting	2/4/6/8/10/12/14/16/18/20/22/24/26/28/30/32/34/36/38/40/42/44/46/48 [pole]	×	×	
	H105	PM rated current	Range is 0 to inverter rated current Amps [A]	×	×	
	H106	PM const R (resistance)	0.001 to 9.999/10.00 to 65.53 [Ω]	×	×	
	H107	PM const Ld (d-axis inductance)	0.01 to 99.99/100.0 to 655.3 [mH]	×	×	
	H108	PM const Lq (q-axis inductance)	0.01 to 99.99/100.0 to 655.3 [mH]	×	×	
	H109	PM const Ke (induction voltage constant)	0.0001 to 6.5535 [V/(rad/s)]	×	×	
	H110	Pm const J (moment of inertia)	0.001 to 9.999/10.00 to 99.99/100.0 to 999.9/1000. to 9999. [kgm <sup>2</sup> ]	×	×	
	H111	Auto PM const R (resistance)	0.001 to 9.999/10.00 to 65.53 [Ω]	×	×	
	H112	Auto PM const Ld (d-axis inductance)	0.01 to 99.99/100.0 to 655.3 [mH]	×	×	
	H113	Auto PM const Lq (q-axis inductance)	0.01 to 99.99/100.0 to 655.3 [mH]	×	×	
	H116	PM speed response	1 to 1000	○	○	100
	H117	PM starting current	20.0 to 100.0 [%]	×	×	70.00
	H118	PM starting time	0.01 to 60.00 [s]	×	×	1.00
	H119	PM stabilization constant	0.0 to 120.0 [%]	×	×	100
H121	PM minimum frequency	0.0 to 25.5 [%]	○	○	8.0	
H122	PM No-Load current	0.00 to 100.0 [%]	×	×	10.00	
H123	PM starting method	00 (disabling) / 01 (enabling)	×	×	00	
H131	PM initial magnet position estimation 0V wait times	0 to 255	×	×	10	
H132	PM initial magnet position estimation detect wait times	0 to 255	×	×	10	
H133	PM initial magnet position estimation detect times	0 to 255	×	×	30	
H134	PM initial magnet position estimation voltage gain	0 to 200	×	×	100	
Others	P001	Operation mode on expansion card 1 error	00 (tripping) / 01 (continuing operation)	×	○	00
	P003	Pulse train input terminal [EA] mode determination	00 (Speed reference, incl. PID) / 01 (control for encoder feedback [1st only]) / 02 (Extended terminal for EzSQ)	×	×	00
Control with FB	P004	Pulse train input mode selection for simple Positioning	00 (Single-phase pulse input) / 01 (2-phase pulse [90° difference] input 1 with EB input) / 02 (2-phase pulse [90° difference] input 2 with EB input) / 03 (Single-phase pulse and direction signal with EB input)	×	×	00
	P011	Encoder pulse-per-revolution (PPR) setting	32 to 1024 [pulse]	×	×	512
	P012	Control pulse setting	00 (simple positioning deactivated) / 02 (simple positioning activated)	×	×	00
	P015	Creep speed setting	"start frequency" to 10.00Hz	×	○	5.00
	P026	Over-speed error detection level setting	0.0 to 150.0 [%]	×	○	115.0
	P027	Speed deviation error detection level setting	0.00 to 99.99/100.0 to 120.0 [Hz]	×	○	10.00

# Function List

[○= Allowed ×= Not permitted]

Code		Function Name	Setting Range	Setting During Operation (allowed or not)	Change During Operation (allowed or not)	Default Setting
Others	P031	Accel /decel time input selection	00 (digital operator)/ 03 (easy sequence)	×	×	00
	P033	Torque command input selection	00 (0 terminal) / 01 (01 terminal) / 03 (digital operator) / 06 (Option)	×	×	00
Torque control	P034	Torque command setting	0 to 200 [%]	○	○	0
	P036	Torque bias mode	00 (disabled the mode) / 01 (digital operator) / 05 (Option)	×	×	00
	P037	Torque bias value	-200 to 200 [%]	○	○	0
	P038	Torque bias polarity selection	00 (as indicated by the sign) / 01 (depending on the operation direction)	×	×	00
	P039	Speed limit for torque-controlled operation (forward rotation)	0.00 to 99.99 / 100.0 to 120.0 [Hz]	×	×	0.00
	P040	Speed limit for torque-controlled operation (reverse rotation)	0.00 to 99.99 / 100.0 to 120.0 [Hz]	×	×	0.00
	P041	Speed / torque change time	0. to 1000. [ms]	×	×	0.
Option	P044	Network comm. Watchdog timer	0.00 to 99.99 [s]	×	×	1.00
Communication option setting	P045	Inverter action on network comm error	00 (tripping) / 01 (tripping after decelerating and stopping the motor) / 02 (ignoring errors) / 03 (stopping the motor after free-running) / 04 (decelerating and stopping the motor)	×	×	01
	P046	Polled I/O output instance number	00 to 20	×	×	00
	P048	Inverter action on network idle mode	00 (tripping) / 01 (tripping after decelerating and stopping the motor) / 02 (ignoring errors) / 03 (stopping the motor after free-running) / 04 (decelerating and stopping the motor)	×	×	01
	P049	Network motor poles setting for RPM	0 / 2 / 4 / 6 / 8 / 10 / 12 / 14 / 16 / 18 / 20 / 22 / 24 / 26 / 28 / 30 / 32 / 34 / 36 / 38	×	×	0
Pulse train input	P055	Pulse train frequency scale	1.0 to 32.0 [kHz]	×	○	25.0
	P056	Time constant of pulse train frequency filter	0.01 to 2.00 [s]	×	○	0.10
	P057	Pulse train frequency bias	-100 to 100 [%]	×	○	0
	P058	Pulse train frequency limit	0 to 100 [%]	×	○	100
Simple positional control	P060 - P067	Multistage position setting 0 - 7	"Position range specification (reverse)" to "Position range specification (forward)"	○	○	0
	P068	Zero-return mode selection	00 (Low) / 01 (High)	○	○	00
	P069	Zero-return direction selection	00 (FW) / 01 (RV)	○	○	01
	P070	Low-speed zero-return frequency	0.00 to 10.00 [Hz]	○	○	5.00
	P071	High-speed zero-return frequency	0.00 to 99.99 / 100.0 to 400.0 [Hz]	○	○	5.00
	P072	Position range specification (forward)	0 to +268435455	○	○	268435455
	P073	Position range specification (reverse)	-268435455 to 0	○	○	-268435455
	P075	Positioning mode selection	00 (With limitation) / 01 (No limitation)	×	×	00
P077	Encoder disconnection timeout	0.0 to 10.0 [s]	○	○	1.0	
Easy sequence programming function	P100 - P131	Easy sequence user parameter U (00) - (31)	0. to 9999. / 1000 to 6553 (10000 to 65535)	○	○	0.
	P140	EzCOM number of data	1 to 5	○	○	5
Peer-to-Peer communication	P141	EzCOM destination 1 address	1 to 247	○	○	1
	P142	EzCOM destination 1 register	0000h to FFFFh	○	○	0000
	P143	EzCOM source 1 register	0000h to FFFFh	○	○	0000
	P144	EzCOM destination 2 address	1 to 247	○	○	2
	P145	EzCOM destination 2 register	0000h to FFFFh	○	○	0000
	P146	EzCOM source 2 register	0000h to FFFFh	○	○	0000
	P147	EzCOM destination 3 address	1 to 247	○	○	3
	P148	EzCOM destination 3 register	0000h to FFFFh	○	○	0000
	P149	EzCOM source 3 register	0000h to FFFFh	○	○	0000
	P150	EzCOM destination 4 address	1 to 247	○	○	4
	P151	EzCOM destination 4 register	0000h to FFFFh	○	○	0000
	P152	EzCOM source 4 register	0000h to FFFFh	○	○	0000
	P153	EzCOM destination 5 address	1 to 247	○	○	5
	P154	EzCOM destination 5 register	0000h to FFFFh	○	○	0000
	P155	EzCOM source 5 register	0000h to FFFFh	○	○	0000
Communication option setting	P160 - P169	Option I / F command register to write 1 - 10	0000h to FFFFh	○	○	0000
	P170 - P179	Option I / F command register to read 1 - 10	0000h to FFFFh	○	○	0000
	P180	Profibus Node address	0 to 125	×	×	0.
	P181	Profibus Clear Node address	00 (clear) / 01 (not clear)	×	×	00
	P182	Profibus Map selection	00 (PPO) / 01 (Conventional)	×	×	00
	P185	CANOpen Node address	0 to 127	×	×	0
	P186	CANOpen speed selection	00 to 08	×	×	06
	P190	CompoNet Node address	00 to 63	×	×	0
	P192	DeviceNet MAC ID	00 to 63	×	×	63
	P195	ML2 frame length	0 (32bytes) / 1 (17bytes)	×	×	00
P196	ML2 Node address	21h to 3Eh	×	×	21h	
User parameter	U001 - U032	User-selected function 1 - 32	no / d001 to P186	○	○	no

## Protective Functions

Name	Cause(s)	Error Code
Over-current event while at constant speed	The inverter output was short-circuited, or the motor shaft is locked or has a heavy load. These conditions cause excessive current for the inverter, so the inverter output is turned OFF. The dual-voltage motor is wired incorrectly.	E01
Over-current event during deceleration		E02
Over-current event during acceleration		E03
Over-current event during other conditions		E04
Overload protection *1	When a motor overload is detected by the electronic thermal function, the inverter trips and turns OFF its output.	E05
Braking resistor overload protection	When the BRD operation rate exceeds the setting of "b090", this protective function shuts off the inverter output and displays the error code.	E06
Over-voltage protection	When the DC bus voltage exceeds a threshold, due to regenerative energy from the motor.	E07
EEPROM error *2	When the built-in EEPROM memory has problems due to noise or excessive temperature, the inverter trips and turns OFF its output to the motor.	E08
Under-voltage error	A decrease of internal DC bus voltage below a threshold results in a control circuit fault. This condition can also generate excessive motor heat or cause low torque. The inverter trips and turns OFF its output.	E09
Current detection error	If an error occurs in the internal current detection system, the inverter will shut off its output and display the error code.	E10
CPU error *2	A malfunction in the built-in CPU has occurred, so the inverter trips and turns OFF its output to the motor.	E11
External trip	A signal on an intelligent input terminal configured as EXT has occurred. The inverter trips and turns OFF the output to the motor.	E12
USP	When the Unattended Start Protection (USP) is enabled, an error occurred when power is applied while a Run signal is present. The inverter trips and does not go into Run Mode until the error is cleared.	E13
Ground fault *2	The inverter is protected by the detection of ground faults between the inverter output and the motor upon during powerup tests. This feature protects the inverter, and does not protect humans.	E14
Input over-voltage	The inverter tests for input over-voltage after the inverter has been in Stop Mode for 100 seconds. If an over-voltage condition exists, the inverter enters a fault state. After the fault is cleared, the inverter can enter Run Mode again.	E15
Inverter thermal trip	When the inverter internal temperature is above the threshold, the thermal sensor in the inverter module detects the excessive temperature of the power devices and trips, turning the inverter output OFF.	E21
CPU communication error	When communication between two CPU fails, inverter trips and displays the error code.	E22
Main circuit error *3	The inverter will trip if the power supply establishment is not recognized because of a malfunction due to noise or damage to the main circuit element.	E25
Driver error *2	An internal inverter error has occurred at the safety protection circuit between the CPU and main driver unit. Excessive electrical noise may be the cause. The inverter has turned OFF the IGBT module output.	E30
Thermistor	When a thermistor is connected to terminals [5] and [L] and the inverter has sensed the temperature is too high, the inverter trips and turns OFF the output.	E35
Braking error	When "01" has been specified for the Brake Control Enable (b120), the inverter will trip if it cannot receive the braking confirmation signal within the Brake Wait Time for Confirmation (b124) after the output of the brake release signal.	E36
Safe stop	Safe stop signal is given.	E37
Low-speed overload protection	If overload occurs during the motor operation at a very low speed, the inverter will detect the overload and shut off the inverter output.	E38
Operator connection	When the connection between inverter and operator keypad failed, inverter trips and displays the error code.	E40
Modbus communication error	When "trip" is selected (C076=00) as a behavior in case of communication error, inverter trips when timeout happens.	E41
EzSQ invalid instruction	The program stored in inverter memory has been destroyed, or the PRG terminal was turned on without a program downloaded to the inverter.	E43
EzSQ nesting count error	Subroutines, if-statement, or for-next loop are nested in more than eight layers	E44
EzSQ instruction error	Inverter found the command which cannot be executed.	E45
EzSQ user trip (0 to 9)	When user-defined trip happens, inverter trips and displays the error code.	E50 to E59
Option error	The inverter detects errors in the option board mounted in the optional slot. For details, refer to the instruction manual for the mounted option board.	E60 to E69
Encoder disconnection	If the encoder wiring is disconnected, an encoder connection error is detected, the encoder fails, or an encoder that does not support line driver output is used, the inverter will shut off its output and display the error code shown on the right.	E80
Excessive speed	If the motor speed rises to "maximum frequency (A004) x over-speed error detection level (P026)" or more, the inverter will shut off its output and display the error code shown on the right.	E81
Positioning range error	If current position exceeds the position range (P072-P073), the inverter will shut off its output and display the error code.	E83

\*1: Reset operations acceptable 10 seconds after the trip.

\*2: The inverter will not accept any reset command after an EEPROM error (E08), CPU error (E11), Ground fault (E14) or Driver error (E30) occurs with error code displayed. Turn off the inverter power once. If error is displayed when the inverter power is turned on subsequently, the internal memory device may have failed or parameters may have not been stored correctly. In such cases, initialize the inverter, and then re-set the parameters.

\*3: Reset cannot be released with the STOP/RESET key. Please reset it with the inverter power or reset terminal (18-RS).

### How to access the details about the present fault

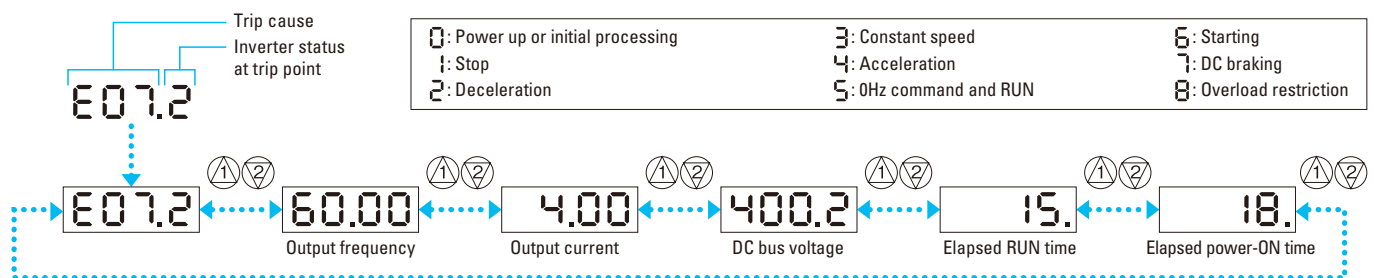

Note: Indicated inverter status could be different from actual inverter behavior. (e.g. When PID operation or frequency given by analog signal, although it seems constant speed, acceleration and deceleration could be repeated in very short cycle.)

# Connecting Diagram

## Source Type Logic

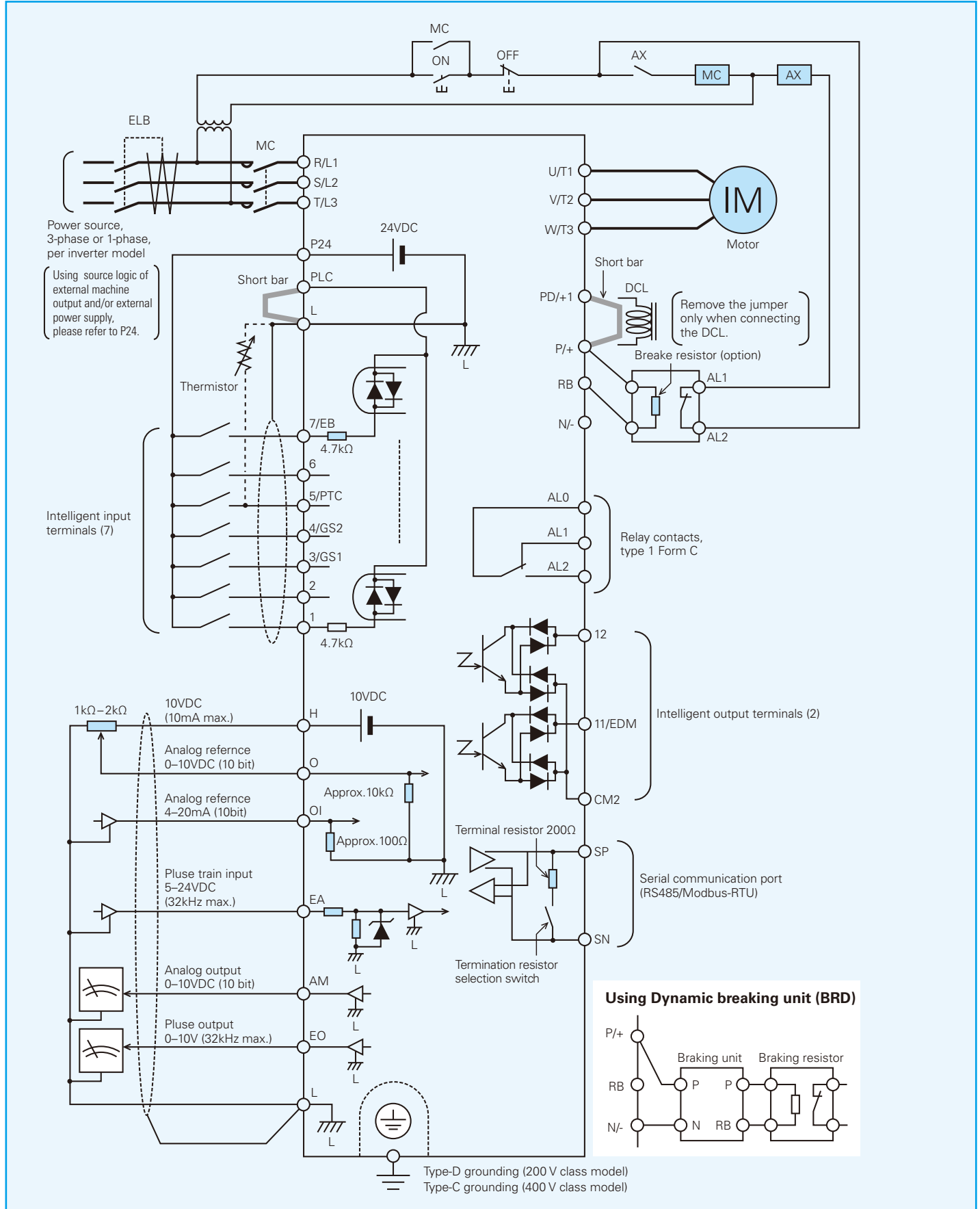

## Sink Type Logic

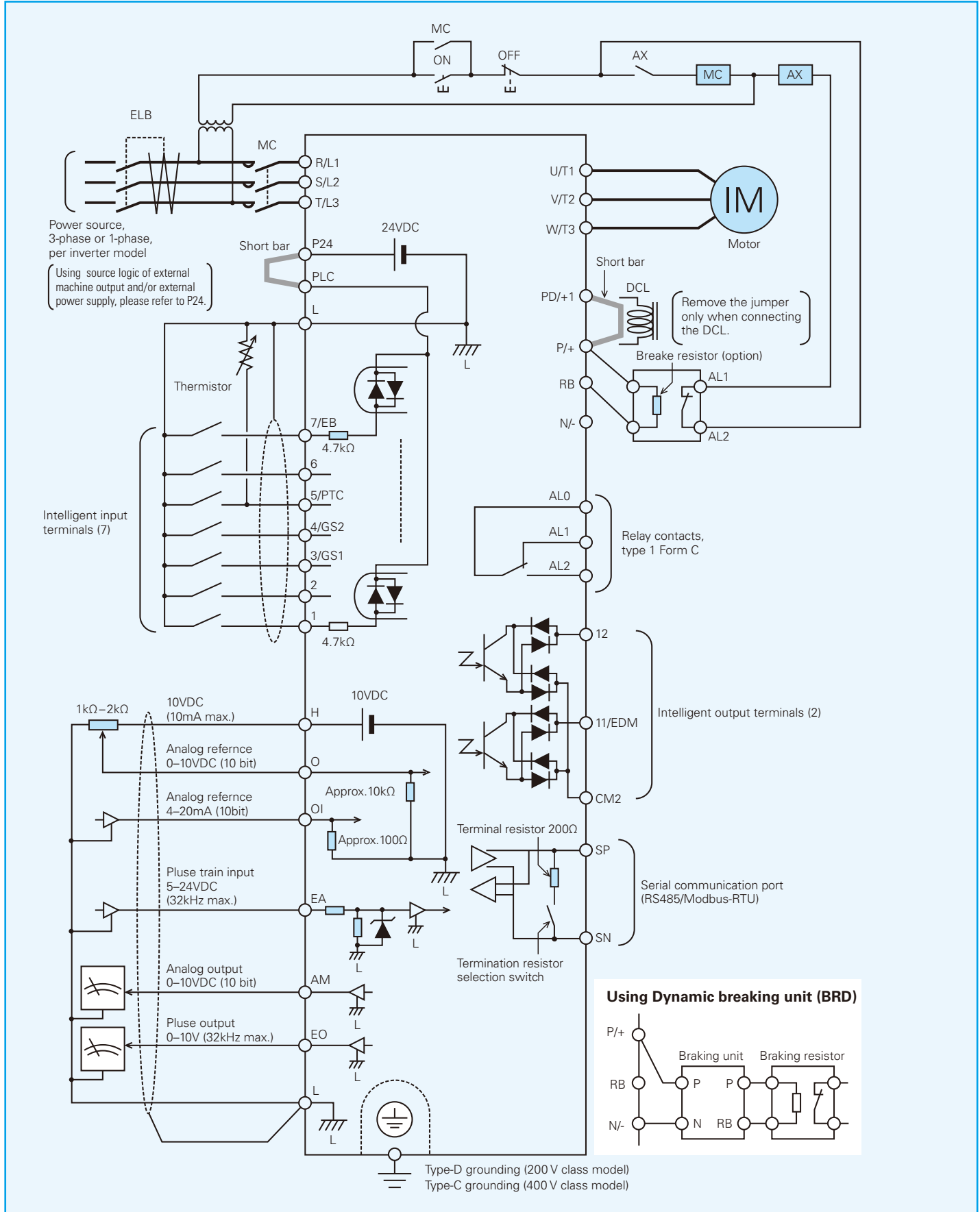

# Connecting to PLC

## Connection with Input Terminals

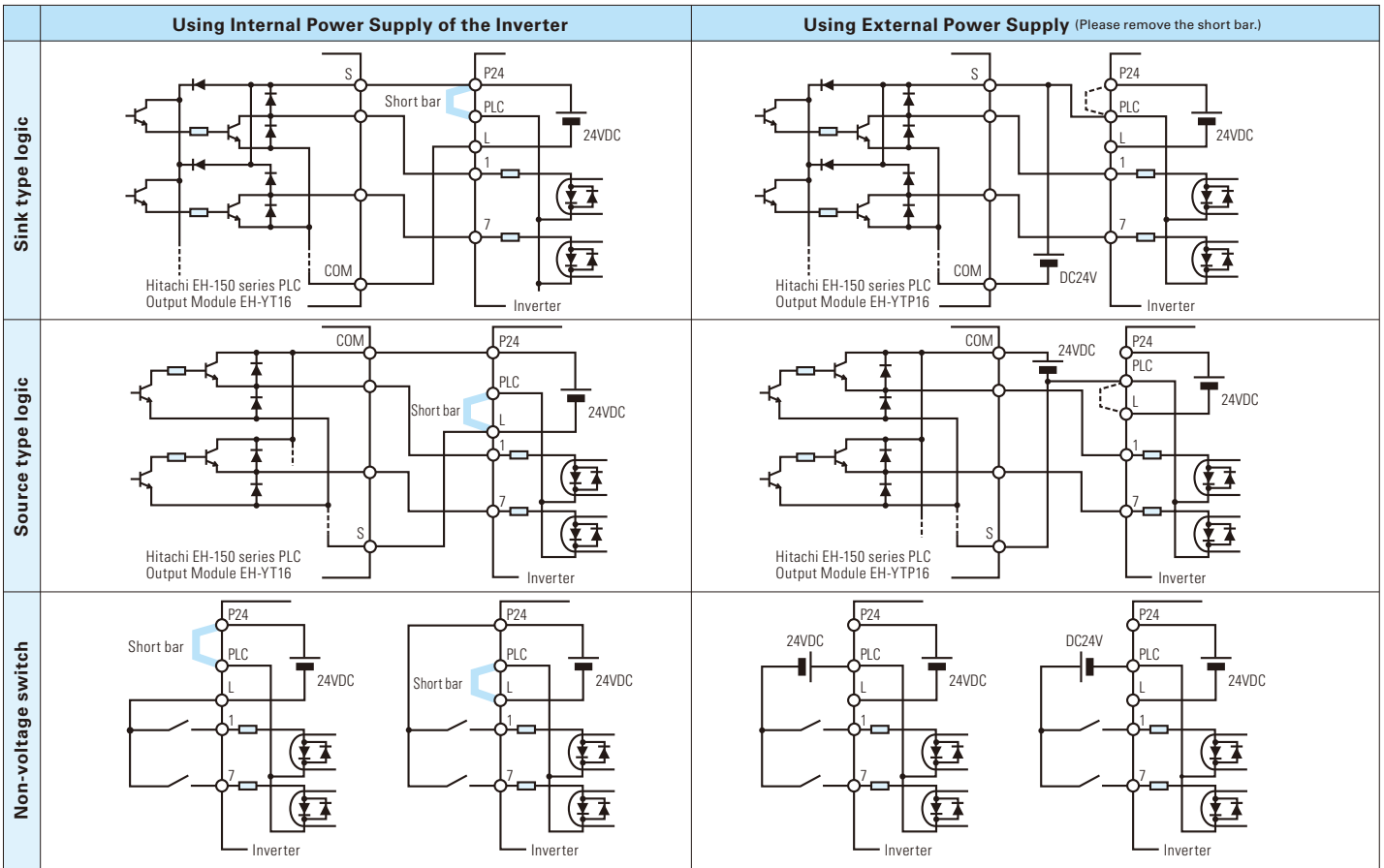

## Connection with Output Terminals

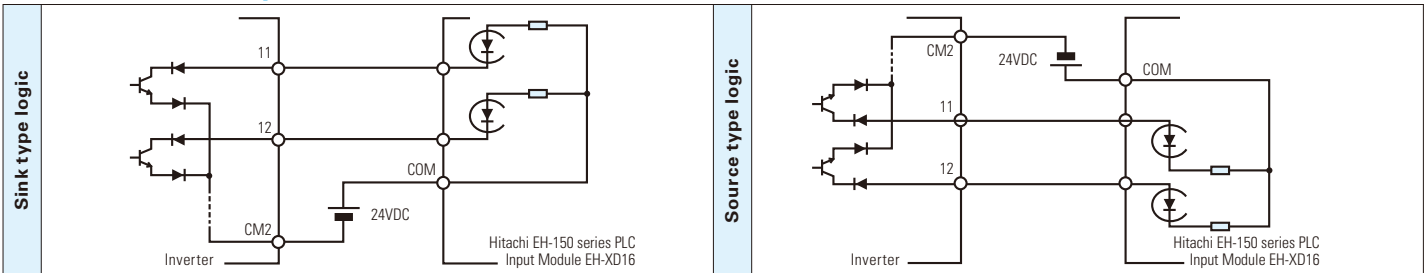

## Attention when inverter plurals is used

When two or more inverters connected to common I/O wiring as shown in the figure at the right are turned on at a different timing, unwanted current flows, establishing a closed circuit, and the inverter is judged to be ON, even though its switch is set to OFF.

To prevent the unwanted current flow, install diodes rated at 50 V/0.1 A at the specified locations.

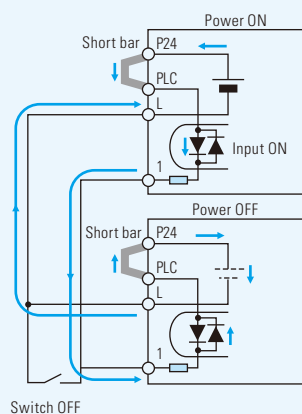

### Example of sink logic

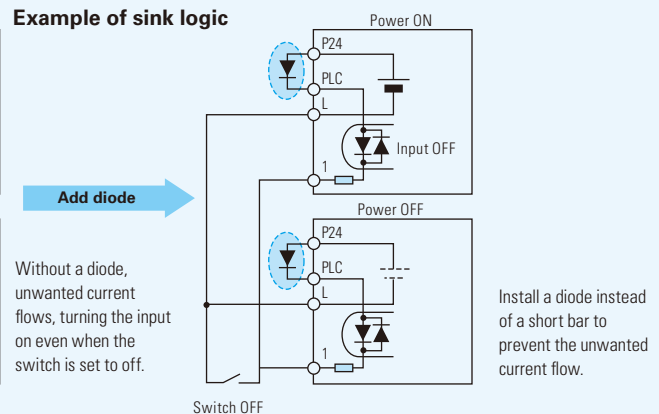



## Wiring and Accessories

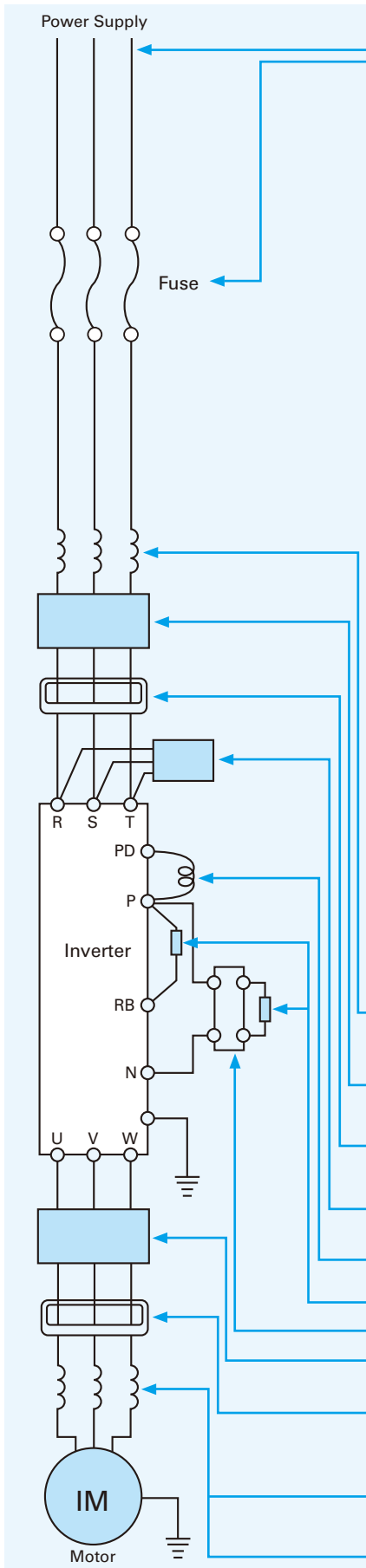

Input Voltage	Motor Output				Inverter Model	Wiring		Fuse (UL-rated, class J, 600V)	
	kW		HP			Power Lines	Signal Lines		
	VT	CT	VT	CT					
1-phase 100V	–	0.4	–	1/2	WJ200-004MF	AWG12/3.3mm <sup>2</sup> (75°C only)	18 to 28 AWG / 0.14 to 0.75 mm <sup>2</sup> shielded wire (see Note 4)	50A	
	–	0.75	–	1	WJ200-007MF	AWG10/5.3mm <sup>2</sup> (75°C only)			
1-phase 200V	0.2	0.1	1/4	1/8	WJ200-001SF	AWG16 / 1.3mm <sup>2</sup> (75°C only)		10A	
	0.4	0.2	1/2	1/4	WJ200-002SF				
	0.55	0.4	3/4	1/2	WJ200-004SF				
	1.1	0.75	1.5	1	WJ200-007SF	AWG12 / 3.3mm <sup>2</sup> (75°C only)			20A
	2.2	1.5	3	2	WJ200-015SF	AWG10 / 5.3mm <sup>2</sup>			30A
	3.0	2.2	4	3	WJ200-022SF				
3-phase 200V	0.2	0.1	1/4	1/8	WJ200-001LF	AWG16 / 1.3mm <sup>2</sup>		10A	
	0.4	0.2	1/2	1/4	WJ200-002LF				
	0.75	0.4	1	1/2	WJ200-004LF				
	1.1	0.75	1.5	1	WJ200-007LF				
	2.2	1.5	3	2	WJ200-015LF	AWG14 / 2.1mm <sup>2</sup> (75°C only)	15A		
	3.0	2.2	4	3	WJ200-022LF	AWG12 / 3.3mm <sup>2</sup> (75°C only)	20A		
	5.5	3.7	7.5	5	WJ200-037LF	AWG10 / 5.3mm <sup>2</sup> (75°C only)	30A		
	7.5	5.5	10	7.5	WJ200-055LF	AWG6 / 13mm <sup>2</sup> (75°C only)	60A		
	11	7.5	15	10	WJ200-075LF				
	15	11	20	15	WJ200-110LF	AWG4 / 21mm <sup>2</sup> (75°C only)	80A		
18.5	15	25	20	WJ200-150LF	AWG2 / 34mm <sup>2</sup> (75°C only)				
3-phase 400V	0.75	0.4	1	1/2	WJ200-004HF	AWG16 / 1.3mm <sup>2</sup>	10A		
	1.5	0.75	2	1	WJ200-007HF				
	2.2	1.5	3	2	WJ200-015HF				
	3.0	2.2	4	3	WJ200-022HF	AWG14 / 2.1mm <sup>2</sup>		15A	
	4.0	3.0	5	4	WJ200-030HF				
	5.5	4.0	7.5	5	WJ200-040HF	AWG12 / 3.3mm <sup>2</sup> (75°C only)			30A
	7.5	5.5	10	7.5	WJ200-055HF	AWG10 / 5.3mm <sup>2</sup> (75°C only)			50A
	11	7.5	15	10	WJ200-075HF				
	15	11	20	15	WJ200-110HF	AWG6 / 13mm <sup>2</sup> (75°C only)			
	18.5	15	25	20	WJ200-150HF	AWG6 / 13mm <sup>2</sup> (75°C only)			

Note 1: Field wiring must be made by a UL-Listed and CSA-certified closed-loop terminal connector sized for the wire gauge involved.

Connector must be fixed by using the crimping tool specified by the connector manufacturer.

Note 2: Be sure to consider the capacity of the circuit breaker to be used.

Note 3: Be sure to use a larger wire gauge if power line length exceeds 66ft. (20 m).

Note 4: Use 18 AWG / 0.75mm<sup>2</sup> wire for the alarm signal wire ([AL0], [AL1], [AL2] terminals).

Name	Function
Input-side AC Reactor	This is useful in suppressing harmonics induced on the power supply lines and for improving the power factor. <b>WARNING:</b> Some applications must use an input-side AC Reactor to prevent inverter damage. See Warning on next page.
EMC filter (for CE applications, see Appendix D)	Reduces the conducted noise on the power supply wiring between the inverter and the power distribution system. Connect to the inverter primary (input) side.
Radio noise filter	Electrical noise interference may occur on nearby equipment such as a radio receiver. This magnetic choke filter helps reduce radiated noise (can also be used on output).
Radio noise filter (use in non-CE applications)	This capacitive filter reduces radiated noise from the main power wires in the inverter (input) side.
DC link choke	Suppress harmonics generated by the inverter. However, it will not protect the input diode bridge rectifier.
Braking register	This is useful for increasing the inverter's control torque for high duty-cycle (on-off) applications, and improving the decelerating capability.
Braking unit	
Output side nose filter	Reduces radiated noise from wiring in the inverter output side.
Radio noise filter	Electrical noise interference may occur on nearby equipment such as a radio receiver. This magnetic choke filter helps reduce radiated noise (can also be used on input).
Output-side AC Reactor	This reactor reduces the vibration in the motor caused by the inverter's switching waveforms, by smoothing the waveform to approximate commercial power quality. It is also useful to reduce harmonics when wiring from the inverter to the motor is more than 10 m in length.
LCR filter	Sine wave shaping filter for output side.

# For Correct Operation

## Precaution for Correct Usage

- Before use, be sure to read through the Instruction Manual to insure proper use of the inverter.
- Note that the inverter requires electrical wiring; a trained specialist should carry out the wiring.
- The inverter in this catalog is designed for general industrial applications. For special applications in fields such as aircraft, outer space, nuclear power, electrical power, transport vehicles, clinics, and underwater equipment, please consult with us in advance.
- For application in a facility where human life is involved or serious losses may occur, make sure to provide safety devices to avoid a serious accident.
- The inverter is intended for use with a three-phase AC motor. For use with a load other than this, please consult with us.

## Application to Motors

### [Application to general-purpose motors]

Operating frequency	The overspeed endurance of a general-purpose motor is 120% of the rated speed for 2 minutes (JIS C4,004). For operation at higher than 60Hz, it is required to examine the allowable torque of the motor, useful life of bearings, noise, vibration, etc. In this case, be sure to consult the motor manufacturer as the maximum allowable rpm differs depending on the motor capacity, etc.
Torque characteristics	The torque characteristics of driving a general-purpose motor with an inverter differ from those of driving it using commercial power (starting torque decreases in particular). Carefully check the load torque characteristic of a connected machine and the driving torque characteristic of the motor.
Motor loss and temperature increase	An inverter-driven general-purpose motor heats up quickly at lower speeds. Consequently, the continuous torque level (output) will decrease at lower motor speeds. Carefully check the torque characteristics vs speed range requirements.
Noise	When run by an inverter, a general-purpose motor generates noise slightly greater than with commercial power.
Vibration	When run by an inverter at variable speeds, the motor may generate vibration, especially because of (a) unbalance of the rotor including a connected machine, or (b) resonance caused by the natural vibration frequency of a mechanical system. Particularly, be careful of (b) when operating at variable speeds a machine previously fitted with a constant speed motor. Vibration can be minimized by (1) avoiding resonance points using the frequency jump function of the inverter, (2) using a tire-shaped coupling, or (3) placing a rubber shock absorber beneath the motor base.
Power transmission mechanism	Under continued, low-speed operation, oil lubrication can deteriorate in a power transmission mechanism with an oil-type gear box (gear motor) or reducer. Check with the motor manufacturer for the permissible range of continuous speed. To operate at more than 60 Hz, confirm the machine's ability to withstand the centrifugal force generated.

### [Application to special motors]

Gear motor	The allowable rotation range of continuous drive varies depending on the lubrication method or motor manufacturer. (Particularly in case of oil lubrication, pay attention to the low frequency range.)
Brake-equipped motor	For use of a brake-equipped motor, be sure to connect the braking power supply from the primary side of the inverter.
Pole-change motor	There are different kinds of pole-change motors (constant output characteristic type, constant torque characteristic type, etc.), with different rated current values. In motor selection, check the maximum allowable current for each motor of a different pole count. At the time of pole changing, be sure to stop the motor. Also see: Application to the 400V-class motor.
Submersible motor	The rated current of a submersible motor is significantly larger than that of the general-purpose motor. In inverter selection, be sure to check the rated current of the motor.
Explosion-proof motor	Inverter drive is not suitable for a safety-enhanced explosion-proof type motor. The inverter should be used in combination with a pressure-proof explosion-proof type of motor. *Explosion-proof verification is not available for WJ200 Series.
Synchronous (MS) motor High-speed (HFM) motor	In most cases, the synchronous (MS) motor and the high-speed (HFM) motor are designed and manufactured to meet the specifications suitable for a connected machine. As to proper inverter selection, consult the manufacturer.
Single-phase motor	A single-phase motor is not suitable for variable-speed operation by an inverter drive. Therefore, use a three-phase motor.

### [Application to the 400V-class motor]

A system applying a voltage-type PWM inverter with IGBT may have surge voltage at the motor terminals resulting from the cable constants including the cable length and the cable laying method. Depending on the surge current magnification, the motor coil insulation may be degraded. In particular, when a 400V-class motor is used, a longer cable is used, and critical loss can occur, take the following countermeasures: (1) install the LCR filter between the inverter and the motor, (2) install the AC reactor between the inverter and the motor, or (3) enhance the insulation of the motor coil.

## Notes on Use

### [Drive]

Run / Stop	Run or stop of the inverter must be done with the keys on the operator panel or through the control circuit terminals. Do not operate by installing an electromagnetic contactor (Mg) in the main circuit.
Emergency motor stop	When the protective function is operating or the power supply stops, the motor enters the free run stop state. When an emergency stop is required or when the motor should be kept stopped, use of a mechanical brake should be considered.
High-frequency run	A max. 400 Hz can be selected on the WJ200 Series. However, a two-pole motor can attain up to approx. 24,000 rpm, which is extremely dangerous. Therefore, carefully make selection and settings by checking the mechanical strength of the motor and connected machines. Consult the motor manufacturer when it is necessary to drive a standard (general-purpose) motor above 60 Hz. A full line of high-speed motors is available from Hitachi.

### [Installation location and operating environment]

Avoid installation in areas of high temperature, excessive humidity, or where moisture can easily collect, as well as areas that are dusty, subject to corrosive gasses, mist of liquid for grinding, or salt. Install the inverter away from direct sunlight in a well-ventilated room that is free of vibration. The inverter can be operated in the ambient temperature range from -10 to 50°C. (Carrier frequency and output current must be reduced in the range of 40 to 50°C.)

### [About the load of frequent repetition use]

About frequent repetition use (crane, elevator, press, washing machine), a power semiconductor (IGBT, a repetition diode, thyristor) in the inverter may come to remarkably have a short life by heat exhaustion. The life can be prolonged by lower a bad electric current. Lengthen acceleration / deceleration time. Lower carrier frequency. or increasing capacity the inverter.

## [About the use in highlands beyond 1,000m above sea level]

When the standard inverter is used at a place beyond 1,000m above sea level because it cool heating element with air, please be careful as follows, But please inquire for the highlands more than 2,500m separately.

### 1. Reduction of the inverter rating current

The density of air decreases by 1% whenever rising by 100m when the altitude exceeds 1,000m. For example, in the case of 2,000m above sea level, it is {2,000(m)- because it becomes 1,000(m)}/100(m)X{-1(%)=-10(%)}, please use with 10(%) reduction (0.9 inverter rating electric current) of a rating current of the inverter.

### 2. Reduction of the breakdown voltage

When using inverter at a place beyond 1,000m, the breakdown voltage decreases as follows.

1,000m or less: 1.00 / 1,500m: 0.95 / 2,000m: 0.90 / 2,500m: 0.85

But please do not perform the withstand pressure test as mention of the instruction manual.

## [Main power supply]

<p><b>Installation of an AC reactor on the input side</b></p>	<p>In the following examples involving a general-purpose inverter, a large peak current flows on the main power supply side, and is able to destroy the converter module. Where such situations are foreseen or the connected equipment must be highly reliable, install an AC reactor between the power supply and the inverter. Also, where influence of indirect lightning strike is possible, install a lightning conductor.</p> <p>(A) The unbalance factor of the power supply is 3% or higher. (Note)                  (B) The power supply capacity is at least 10 times greater than the inverter capacity (the power supply capacity is 500 kVA or more).                  (C) Abrupt power supply changes are expected.</p> <p>Examples: (1) Several inverters are interconnected with a short bus.                  (2) A thyristor converter and an inverter are interconnected with a short bus.                  (3) An installed phase advance capacitor opens and closes.</p> <p>In cases (A), (B) and (C), it is recommended to install an AC reactor on the main power supply side.</p> <p>Note: Example calculation with <math>V_{RS} = 205V</math>, <math>V_{ST} = 201V</math>, <math>V_{TR} = 200V</math> (<math>V_{RS}</math> : R-S line voltage, <math>V_{ST}</math> : S-T line voltage, <math>V_{TR}</math> : T-R line voltage)</p> <p>Unbalance factor of voltage = <math>\frac{\text{Max. line voltage (min.)} - \text{Mean line voltage}}{\text{Mean line voltage}} \times 100</math></p> $= \frac{V_{RS} - (V_{RS} + V_{ST} + V_{TR})/3}{(V_{RS} + V_{ST} + V_{TR})/3} \times 100 = \frac{205 - 202}{202} \times 100 = 1.5 (\%)$
<p><b>Using a private power generator</b></p>	<p>An inverter run by a private power generator may overheat the generator or suffer from a deformed output voltage waveform of the generator. Generally, the generator capacity should be five times that of the inverter (kVA) in a PWM control system, or six times greater in a PAM control system.</p>

## Notes on Peripheral Equipment Selection

<p><b>Wiring connections</b></p>	<p>(1) Be sure to connect main power wires with R (L1), S (L2), and T (L3) terminals (input) and motor wires to U (T1), V (T2), and W (T3) terminals (output). (Incorrect connection will cause an immediate failure.)                  (2) Be sure to provide a grounding connection with the ground terminal (⊕).</p>
<p><b>Wiring between inverter and motor</b></p>	<p><b>Electro-magnetic contactor</b></p> <p>When an electromagnetic contactor is installed between the inverter and the motor, do not perform on-off switching during running operation.</p> <p><b>Thermal relay</b></p> <p>When used with standard applicable output motors (standard three-phase squirrel-cage four-pole motors), the WJ200 Series does not need a thermal relay for motor protection due to the internal electronic protective circuit. A thermal relay, however, should be used:</p> <ul style="list-style-type: none"> <li>during continuous running outside a range of 30 to 60 Hz.</li> <li>for motors exceeding the range of electronic thermal adjustment (rated current).</li> <li>when several motors are driven by the same inverter; install a thermal relay for each motor.</li> <li>The RC value of the thermal relay should be more than 1.1 times the rated current of the motor. Where the wiring length is 10 m or more, the thermal relay tends to turn off readily. In this case, provide an AC reactor on the output side or use a current sensor.</li> </ul>
<p><b>Installing a circuit breaker</b></p>	<p>Install a circuit breaker on the main power input side to protect inverter wiring and ensure personal safety. Choose an inverter-compatible circuit breaker. The conventional type may malfunction due to harmonics from the inverter. For more information, consult the circuit breaker manufacturer.</p>
<p><b>Wiring distance</b></p>	<p>The wiring distance between the inverter and the remote operator panel should be 20 meters or less. When this distance is exceeded, use CVD-E (current-voltage converter) or RCD-E (remote control device). Shielded cable should be used on the wiring. Beware of voltage drops on main circuit wires. (A large voltage drop reduces torque.)</p>
<p><b>Earth leakage relay</b></p>	<p>If the earth leakage relay (or earth leakage breaker) is used, it should have a sensitivity level of 15 mA or more (per inverter).</p>
<p><b>Phase advance capacitor</b></p>	<p>Do not use a capacitor for power factor improvement between the inverter and the motor because the high-frequency components of the inverter output may overheat or damage the capacitor.</p>

## High-frequency Noise and Leakage Current

(1) High-frequency components are included in the input/output of the inverter main circuit, and they may cause interference in a transmitter, radio, or sensor if used near the inverter.

The interference can be minimized by attaching noise filters (option) in the inverter circuitry.

(2) The switching action of an inverter causes an increase in leakage current. Be sure to ground the inverter and the motor.

## Lifetime of Primary Parts

Because a DC bus capacitor deteriorates as it undergoes internal chemical reaction, it should normally be replaced every 10 years. (10 years is not the guaranteed lifespan but rather, the expected design lifeplan.) Be aware, however, that its life expectancy is considerably shorter when the inverter is subjected to such adverse factors as high temperatures or heavy loads exceeding the rated current of the inverter.

JEMA standard is the 5 years at ambient temperature 40°C used in 12 hours daily. (according to the "Instructions for Periodic Inspection of General-Purpose Inverter" (JEMA))

Also, such moving parts as a cooling fan should be replaced. Maintenance inspection and parts replacement must be performed by only specified trained personnel.

